

M3 System

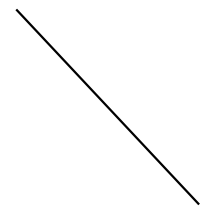

M3 System
Matter forms
emotions



M3 System
Matter
forms
emotions

M3 System

Summary

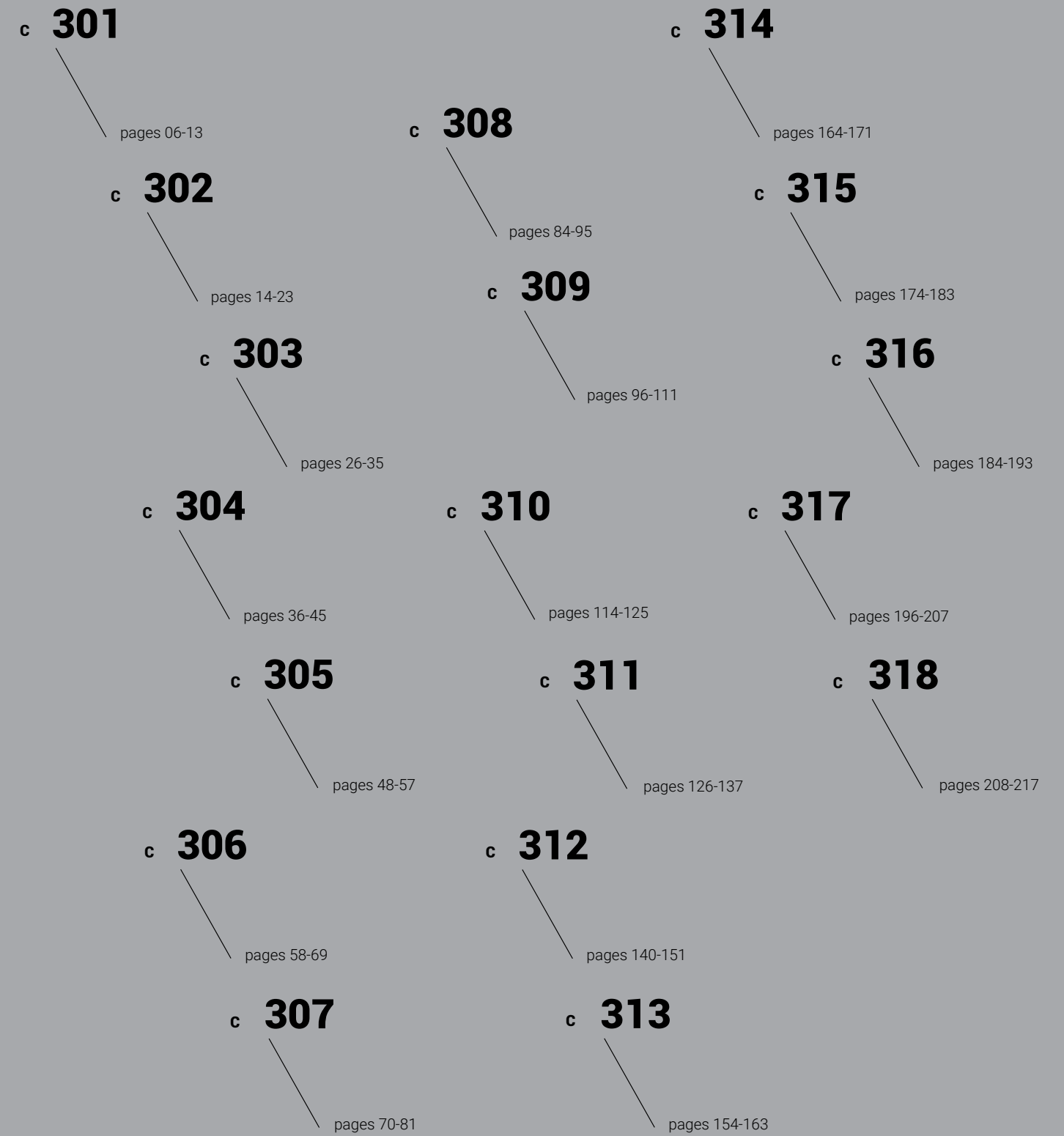

M3 System

Matter forms emotions

Levigata dal lavoro incessante dell'acqua, la pietra si racconta con le sue infinite forme scolpite come opere uniche e irripetibili. In queste stanze, ascoltiamo l'eco del vento riflettersi sulle superfici talvolta tattili, talvolta lisce come specchi per invitarci a vivere il bagno in un'intima connessione con la materia, dove ogni cosa da origine alla creazione.



— Smoothed by the incessant work of water, stone tells its story with its infinite forms carved as unique and unrepeatable works. In these rooms, we hear the echo of the wind reflected on surfaces that are sometimes tactile, sometimes as smooth as mirrors, inviting us to experience the bathroom in an intimate connection with the material, where everything gives origin to creation.

— Lissée par le travail incessant de l'eau, la pierre raconte son histoire avec ses formes infinies sculptées comme des œuvres uniques et non reproductibles. Dans ces pièces, nous entendons l'écho du vent qui se reflète sur des surfaces tantôt tactiles, tantôt lisses comme des miroirs, nous invitant à vivre la salle de bains dans un rapport intime avec la matière, où tout donne lieu à la création.

— Geplättet durch die unablässige Arbeit des Wassers, erzählt der Stein seine Geschichte mit seinen unendlichen Formen, die zu einzigartigen und unwiederholbaren Werken geformt wurden. In diesen Räumen hören wir das Echo des Windes, das sich auf den mal fühlbaren, mal spiegelglatten Oberflächen widerspiegelt und uns einlädt, das Bad in einer intimen Verbindung mit dem Material zu erleben, in dem alles zur Schöpfung führt.

— Alisada por el incesante trabajo del agua, la piedra cuenta su historia con sus infinitas formas esculpidas como obras únicas e irrepitibles. En estas salas, escuchamos el eco del viento reflejado en superficies a veces táctiles, a veces lisas como espejos, que nos invitan a vivir el baño en una conexión íntima con la materia, donde todo da lugar a la creación.



___ Quanto rimaniamo affascinati dalla straordinaria, intima bellezza e semplicità della natura. Paesaggi mozzafiato avvolti da limpide cascate d'acqua che li rendono così unici e indimenticabili. I nostri arredi a terra, con sistema a muro in finitura Cannetè laccato opaco, sono uno spazio personale dal carattere deciso e ricercato. I frontali inclinazione 45° godono di uno spazio interno organizzato. Il vano superiore crea un'area pratica dove appoggiare accessori e oggetti di uso quotidiano.

___ How fascinated we are by the extraordinary, intimate beauty and simplicity of nature. Breathtaking landscapes enveloped in clear waterfalls that make them so unique and unforgettable. Our floor-standing furniture, with a wall system in matt lacquered Cannetè finish, is a personal space with a strong, sophisticated character. The 45° edges fronts enjoy an organised interior space. The upper compartment creates a practical area for storing accessories and everyday objects.

___ Comme nous sommes fascinés par la beauté extraordinaire et intime et la simplicité de la nature.

Des paysages à couper le souffle entourés de cascades claires qui les rendent si uniques et inoubliables. Nos meubles au sol, avec système mural en finition laquée mate Cannetè, sont un espace personnel au caractère décisif et raffiné. Les façades inclinées à 45° bénéficient d'un espace intérieur organisé. Le compartiment supérieur crée un espace pratique où placer des accessoires et des objets du quotidien.

___ Wie fasziniert sind wir von der außergewöhnlichen, intimen Schönheit und Einfachheit der Natur. Atemberaubende Landschaften, umhüllt von klaren Wasserfällen, die sie so einzigartig und unvergesslich machen. Unsere bodenstehenden Möbel mit einem Wandsystem aus matt lackiertem Cannetè-Oberfläche sind ein persönlicher Raum mit einem starken und raffinierten Charakter. Die um 45° geneigten Fronten bieten einen organisierten Innenraum. Das obere Fach schafft eine praktische Ablagefläche für Accessoires und Alltagsgegenstände.

___ Cómo nos fascina la extraordinaria e íntima belleza y sencillez de la naturaleza. Impresionantes paisajes envueltos en claras cascadas que los hacen tan únicos e

inolvidables. Nuestros muebles al suelo, con sistema de pared en acabado Cannetè lacado mate, constituyen un espacio personal de carácter fuerte y sofisticado. Los frentes a 45° permiten disfrutar de un espacio interior organizado. El compartimento superior crea una zona práctica para guardar accesorios y objetos cotidianos.



Waterfall _ nature





_____ Il lavabo a terra in Cristalplant esternamente verniciato, diventa una scultura essenziale all'interno del bagno.
_____ The floor-standing washbasin externally coated in Cristalplant becomes an essential sculpture within the bathroom. _____ La vasque au sol en Cristalplant, peint à l'extérieur, devient une sculpture essentielle à l'intérieur de la salle de bain.
_____ Der bodenstehende Waschtisch aus außen beschichtetem Cristalplant wird zu einer unverzichtbaren Skulptur im Bad. _____ El lavabo al suelo en Cristalplant revestido exteriormente se convierte en una escultura esencial dentro del cuarto de baño.





_____ Frontale minimalista in Cannelé laccato opaco simmetrico Tipo B in verticale, decora e garantisce l'ordine all'interno del bagno. _____ Minimalist front panel in symmetrical vertical Type B matt lacquered Cannelé decorates and ensures order inside the bathroom. _____ Façade minimaliste en Cannelé laqué mat symétrique Type B vertical, décore et garantit l'ordre à l'intérieur de la salle de bain. _____ Minimalistische Front aus symmetrischem, matt lackiertem Cannelé Typ B vertikal, dekoriert und sorgt für Ordnung im Bad. _____ El panel frontal minimalista en Cannelé simétrico lacado mate tipo B decora y garantiza el orden en el interior del cuarto de baño.





___ Ambienti fatti di trame materiche che narrano storie e territorio, incontrano la trasparenza e l'autenticità dell'acqua. Il sistema a muro in legno Rovere Sabbia arreda e contiene, nella verticalità degli elementi, estetica e funzionalità connotato da genio e maestria, made in Italy.

___ Environments made of material textures that tell stories and territory, meet the transparency and authenticity of water. The Rovere sabbia wall system furnishes and contains, in the verticality of the elements, aesthetics and functionality characterised by genius and craftsmanship, made in Italy.

___ Des environnements faits de textures matérielles qui racontent des histoires et du territoire, rencontrent la transparence et l'authenticité de l'eau. Le système au mur en bois plaqué Rovere Sabbia fournit et contient, dans la verticalité des éléments, une esthétique et une fonctionnalité caractérisées par le génie et la maîtrise, made in Italy.

___ Umgebungen aus Materialtexturen, die Geschichten und Territorien erzählen, treffen auf die Transparenz und Authentizität des Wassers. Das Holzwandssystem Rovere Sabbia bietet in der Vertikalität der Elemente eine Ästhetik und Funktionalität, die sich durch Genialität und Handwerkskunst auszeichnet, Made in Italy.

___ Ambientes hechos de texturas materiales que cuentan historias y territorio, se encuentran con la transparencia y la autenticidad del agua. El sistema de pared Rovere sabbia amuebla y contiene, en la verticalidad de los elementos, estética y funcionalidad caracterizadas por el genio y la artesanía, made in Italy.



Caorle _ Italy





_____ La base è disponibile in 4 profondità: 17 cm, 21 cm, 27 cm e 36,5 cm. Basi che creano una comoda e pratica superficie d'appoggio per gli accessori di tutti i giorni.

_____ The base is available in 4 depths: 17 cm, 21 cm, 27 cm and 36.5 cm. Bases that create a convenient and practical storage surface for everyday accessories. _____ Le meuble bas est disponible en 4 profondeurs: 17 cm, 21 cm, 27 cm et 36,5 cm. Des meubles bas qui créent une surface de soutien confortable et pratique pour les accessoires de tous les jours. _____ Der Unterschränke in 4 Tiefen erhältlich: 17 cm, 21 cm, 27 cm und 36,5 cm. Unterschränke, die eine bequeme und praktische Ablagefläche für alltägliche Accessoires bieten. _____ La base está disponible en 4 profundidades: 17 cm, 21 cm, 27 cm y 36,5 cm. Bases que crean una superficie de almacenamiento cómoda y práctica para los accesorios de uso diario.



_____ Lavabo Ascot in Gres Calacatta Oro Venato opaco L. 80 H. 29,7 cm con bordo dritto. Una superficie venata particolarmente ricercata, dona raffinatezza alla composizione. _____ Ascot washbasin in matt Gres Calacatta Oro Venato W. 80 H. 29,7 cm with straight edge. A particularly refined veined surface lends refinement to the composition. _____ Vasque Ascot en Grès Cérame Calacatta Oro Venato mat L. 80 H. 29,7 cm à bord droit. Une surface veinée particulièrement raffinée confère de la finesse à la composition. _____ Waschbecken Ascot aus mattem Gres Calacatta Oro Venato B. 80 H. 29,7 cm mit geradem Rand. Eine besonders raffiniert geäderte Oberfläche verleiht der Komposition Raffinesse. _____ Lavabo Ascot de Gres Calacatta Oro Venato mate L. 80 Alt. 29,7 cm con borde recto. Una superficie vetada especialmente refinada confiere refinamiento a la composición.



M3 System _____ Matter forms emotions

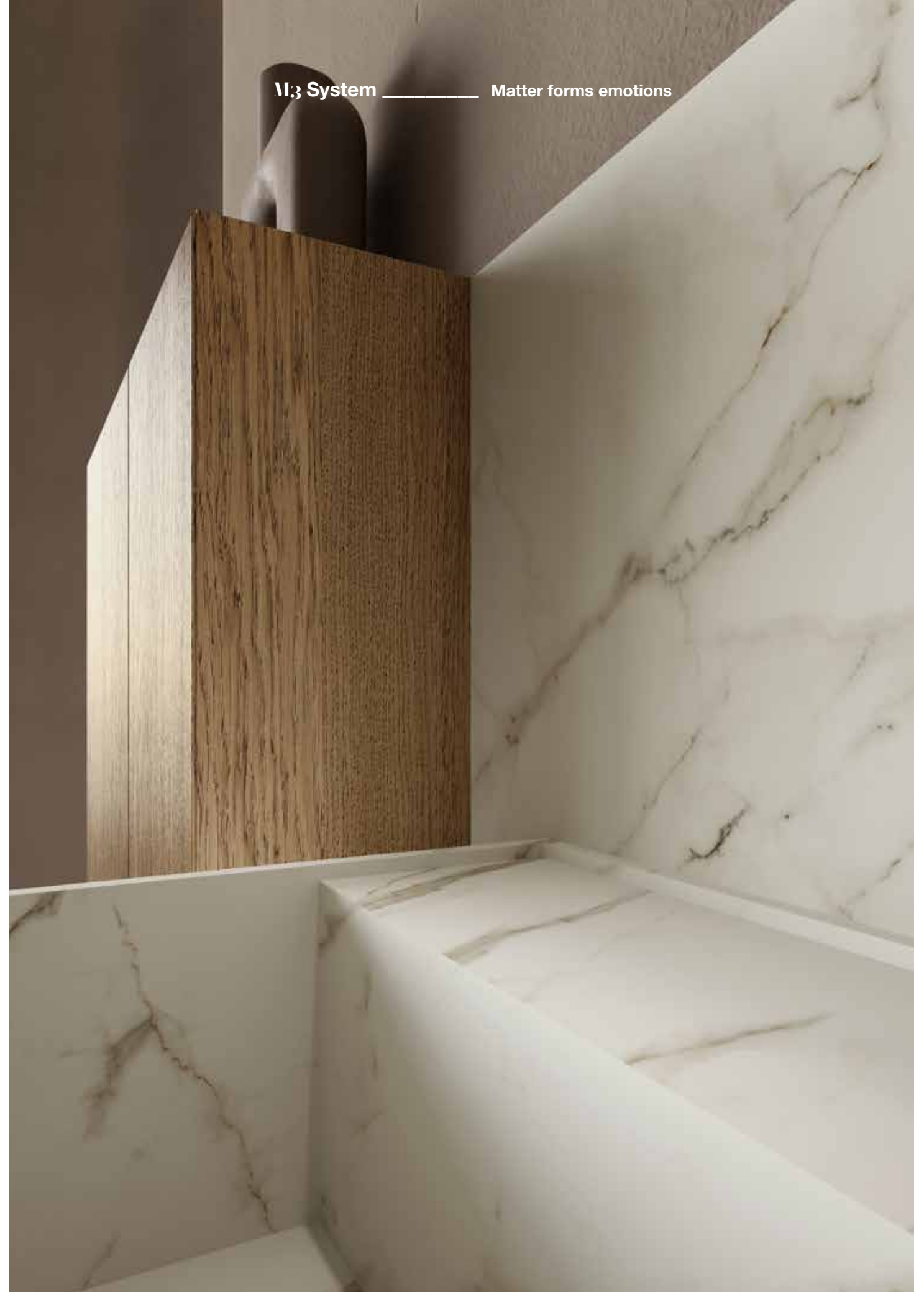

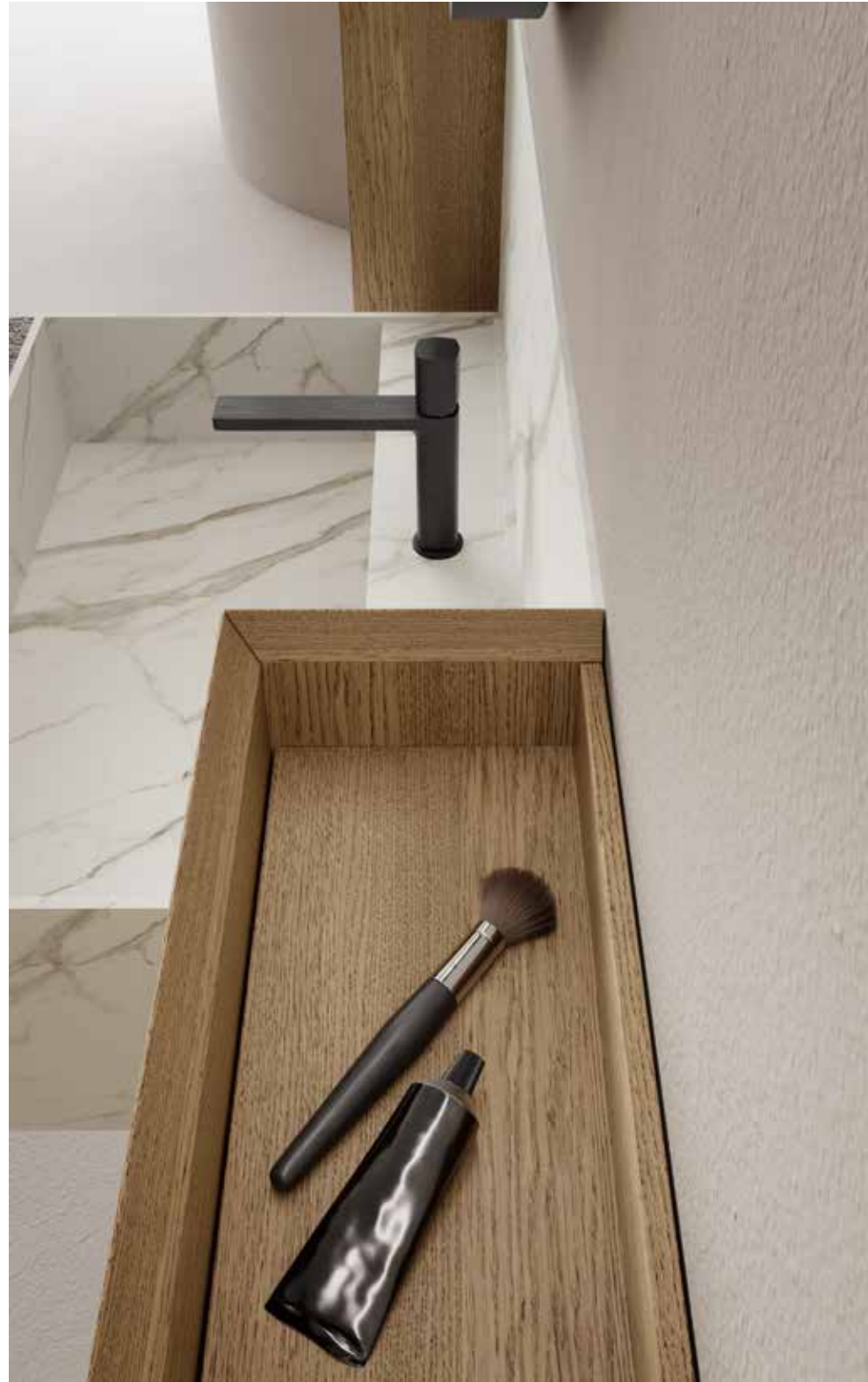

Materials Suggestions | A |

- _01 Legno Rovere Naturale - 06B
- _02 Legno Rovere Sabbia - 06C
- _03 Gres Limestone Moon - TRE
- _04 Gres Emperador Lucido - TR3
- _05 Gres Ossido Bruno - TQT
- _06 Laccato Verde Polvere - 234





___ Rocce, dalle forme
singolari e pattern naturali,
si lasciano plasmare dall'acqua
fresca che sembra imprimere
loro il carattere distintivo
che le rende così uniche.
Pietra, colore e forma
si integrano per arredare
in equilibrio e cura
dal benessere naturale
nell'intimità della stanza
da bagno.

___ Rocks, with their unique
shapes and natural patterns,
let themselves be shaped by
the fresh water that seems to
imprint them with the distinctive
character that makes them
so unique. Stone, colour
and form come together
to furnish the intimate bathroom
with balance and care.

___ Les roches, avec leurs
formes singulières et leurs
motifs naturels, se laissent
façonner par l'eau douce qui
semble leur donner le caractère
distinctif qui les rend si uniques.
La pierre, la couleur et la forme
sont intégrées pour meubler en
équilibre et en soin du bien-être
naturel dans l'intimité de la salle
de bain.

___ Die Felsen mit ihren
einzigartigen Formen und
natürlichen Mustern lassen
sich durch das frische Wasser
formen, das ihnen den
unverwechselbaren Charakter
zu verleihen scheint, der sie so
einzigartig macht. Stein, Farbe
und Form kommen zusammen,
um das intime Badezimmer
mit Gleichgewicht und
Sorgfalt einzurichten.

___ Las rocas, con sus formas
únicas y sus dibujos naturales,
se dejan moldear por el agua
dulce que parece imprimirles el
carácter distintivo que las hace
tan únicas. Piedra, color y forma
se unen para amueblar el baño
íntimo con equilibrio y cuidado.



Water_nature





_____ La Lampada a sospensione NET, verniciata Nero, si inserisce in modo complementare in questo angolo fatto di volumi e geometrie dando forma "sottile" all'originalità.

_____ The NET pendant lamp, painted black, fits complementarily into this corner made of volumes and geometries, giving "subtle" form to originality.

_____ L'applique à suspension NET, peinte en noir, s'intègre de manière complémentaire dans ce coin fait de volumes et de géométries, donnant une forme « subtile » à l'originalité.

_____ Die schwarz lackierte Hängeleuchte NET fügt sich komplementär in diese Ecke von Volumen und Geometrie ein und verleiht der Originalität eine "subtilen" Form.

_____ La lámpara colgante NET, pintada de negro, se integra en este rincón de volúmenes y geometrías de forma complementaria, dando forma "sutil" a la originalidad.

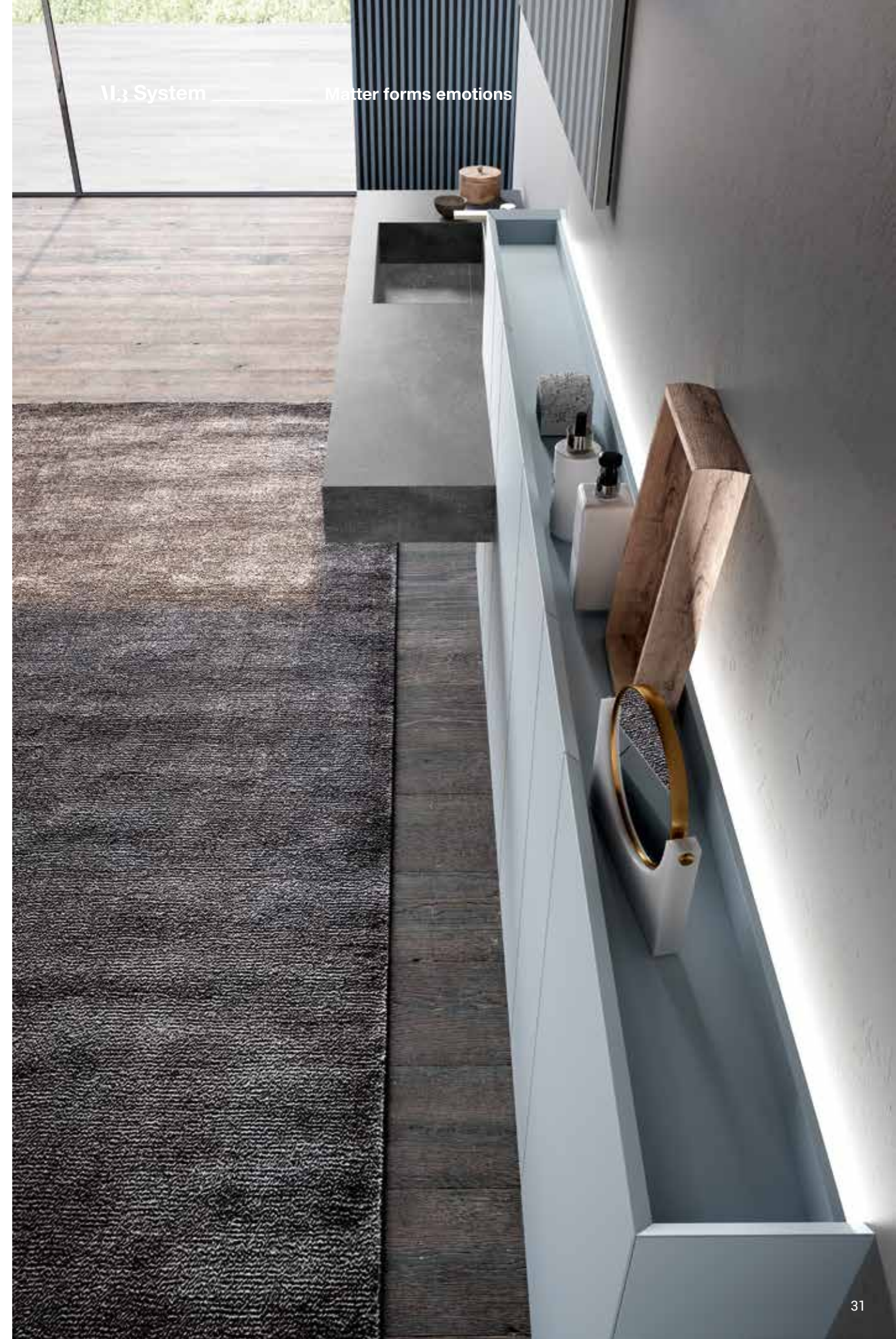



M3 System _____ Matter forms emotions

_____ Lavabo Top. Sp. 13 cm HPL Unicolor Rox Black con vasca Strip 60 cm. _____ Washbasin Top. 13 cm thick HPL Unicolor Rox Black with Strip 60 cm washbasin. _____ Plan vasque 13 cm d'épaisseur HPL Unicolor Rox Black avec vasque Strip de 60 cm. _____ Waschtischplatte 13 cm starkes HPL Unicolor Rox Black mit Strip 60 cm Waschbecken. _____ Encimera HPL Unicolor Rox Negro de 13 cm de grosor con lavabo Strip de 60 cm.

_____ Elementi sospesi in Laccato Opaco Carta da Zuccherò (247), con estetica lineare e squadrata dispongono di comodi spazi interni dove posizionare accessori di uso quotidiano.

_____ Wall-mounted elements in Laquered matt Carta da Zuccherò (247), with linear and square aesthetics have convenient interior spaces where everyday accessories can be placed.

_____ Les éléments suspendus en laque mate Carta da Zuccherò (247), avec esthétique linéaire et carrée, disposent d'espaces intérieurs confortables où placer des accessoires de tous les jours.

_____ Die Wandelemente aus Carta da Zuccherò Matt (247) lackiert mit ihrer geradlinigen und quadratischen Ästhetik verfügen über praktische Innenräume, in denen alltägliche Accessoires untergebracht werden können.

_____ Los elementos murales en Laca Mate Carta da Zuccherò (247), de estética lineal y cuadrada, disponen de cómodos espacios interiores donde colocar los accesorios de uso diario.





___ Riflessi di luce si esprimono con delicati movimenti dell'acqua trasmettendo un senso di pace e di relax. Le superfici in Canneté disegnano linee tridimensionali attraverso cromie ispirate alla natura. Ciascun elemento concorre a stabilire armonia ed equilibrio nella zona del bagno intimo e solare. Particolare fascino è rappresentato dai nuovi top in essenza di Rovere, caratterizzati da bordi a 45°.

___ Reflections of light are expressed with gentle water movements, conveying a sense of peace and relaxation. The Canneté surfaces draw three-dimensional lines through colours inspired by nature. Each element contributes to establishing harmony and balance in the intimate, cheerful bathroom area. Particular appeal is provided by the new Oak veneered tops with 45° edges.

___ Les reflets de la lumière s'expriment avec des mouvements délicats de l'eau transmettant un sentiment de paix et de détente. Les surfaces en Canneté dessinent des lignes tridimensionnelles à travers des couleurs inspirées de la nature. Chaque élément contribue à établir l'harmonie et l'équilibre dans la salle de bain intime et ensoleillée. Un charme particulier est représenté par les nouveaux plateaux en Chêne plaqué, caractérisés par des bords à 45°.

___ Lichtreflexe werden durch sanfte Wasserbewegungen zum Ausdruck gebracht und vermitteln ein Gefühl von Ruhe und Entspannung. Die Canneté-Oberflächen zeichnen dreidimensionale Linien durch von der Natur inspirierte Farben. Jedes Element trägt dazu bei, Harmonie und Gleichgewicht im intimen, sonnigen Badbereich herzustellen. Besonders reizvoll sind die neuen essenza di Rovere Waschtischplatten mit 45°-Kanten.

___ Los reflejos de luz se expresan con suaves movimientos del agua, transmitiendo una sensación de paz y relajación. Las superficies Canneté dibujan líneas tridimensionales a través de colores inspirados en la naturaleza. Cada elemento contribuye a establecer la armonía y el equilibrio en la zona de baño íntima y alegre. Las nuevas encimeras de Rovere bordes a 45° aportan un atractivo especial.



Litorale Grado _F.V.G_ Italy



_____ Colonne con vano a giorno in Essenza di Rovere con schienale personalizzabile in Laccato Verde Salvia Opaco (242).
 _____ Columns with open compartment in Oak Essence with customisable back panel in Laquered Matt Verde Salvia (242).
 _____ Colonnes avec niche ouverte en Chêne plaqué avec fond personnalisable en laque mate Verde Salvia (242).
 _____ Hochschränke mit offenem Fach in Essenza di Rovere mit anpassbarem Rücken in Lack matt Verde Salvia (242).
 _____ Columnas con compartimento abierto en Essenza Rovere con panel trasero personalizable en Verde Salvia lacado mate (242).





_____ Lavabo FIVE 02 in Cristalplant Bianco Opaco personalizzabile con colorazione esterna in Verde Salvia Opaco (242). Ha una forma sinuosa e morbida. _____ FIVE 02 washbasin in Matt White Cristalplant that can be customised in Laquered Matt Verde Salvia (242). It has a sinuous, soft shape. _____ Vasque FIVE 02 en Cristalplant Bianco Opaco personnalisable avec couleur extérieure en Verde Salvia mat (242). Il a une forme sinueuse et douce. _____ Der Waschtisch FIVE 02 in Cristalplant Weiß matt kann mit einem Außenanstrich in Verde Salvia matt (242) versehen werden. Er hat eine geschwungene und weiche Form. _____ Lavabo FIVE 02 en Cristalplant Bianco Mate personalizable en Salvia Verde Mate Lacado (242). Tiene una forma sinuosa y suave.



_____ Cannetè tipo A (asimmetrico) in orizzontale Laccato Verde Salvia Opaco (242).
 _____ Cannetè type A (asymmetrical) in horizontal Laquered Matt Verde Salvia (242).
 _____ Cannetè type A (asymétrique) horizontal laqué Verde Salvia mat (242).
 _____ Cannetè Typ A (asymmetrisch) in horizontal Lackiert Verde Salvia Opaco (242).
 _____ Cannetè tipo A (asimétrico) en Lacado Matt Verde Salvia (242) horizontal.



Materials Suggestions | B |

- _01 Gres Travertino Lucido - TR6
- _02 Legno Rovere Fumo - 06F
- _03 Laccato Arancio Zucca - 209
- _04 Gres Sahara Noir Lucido - TQJ
- _05 Legno Rovere Avena - 06E
- _06 Gres Pietra Piasentina Taupe - TQQ

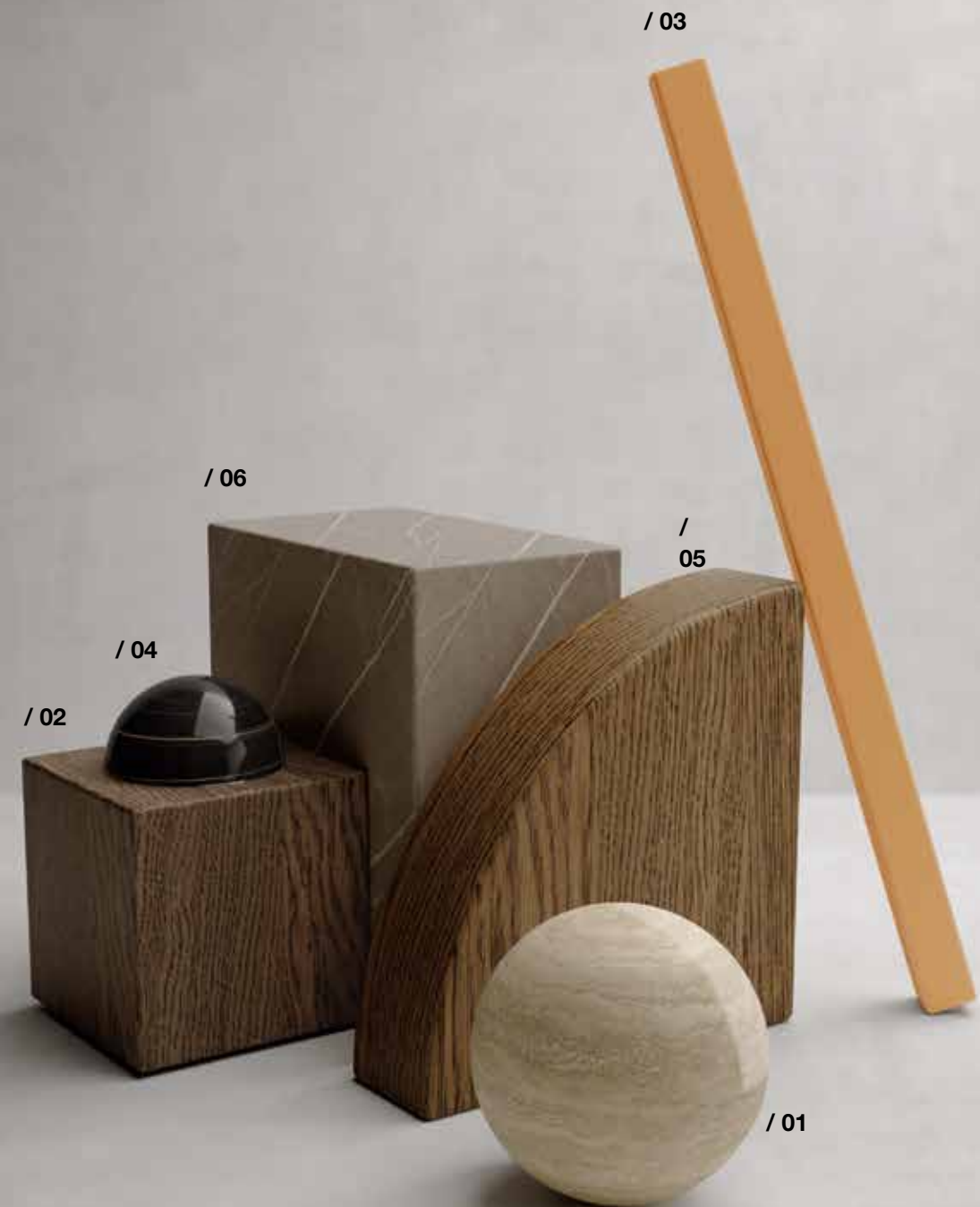



___ **Forme e volumi irregolari scolpiti dall'acqua definiscono confini e caratterizzano aree e luoghi. Come le basi e colonne in Canneté tipo A asimmetrico verticale che con la loro delicata personalità arricchiscono la stanza da bagno. Le colonne dispongono di maniglia gola laterale consentendo di non interrompere in modo invadente il ritmo visivo del frontale, che rimane così libero ed equilibrato.**

___ Irregular shapes and volumes sculpted by water define boundaries and characterise areas and places. Like the bases and columns in asymmetrical vertical Canneté type A, that enrich the bathroom with their delicate personality. The columns have a side groove handle so that the visual rhythm of the front is not intrusively interrupted, thus remaining free and balanced..

___ Des formes irrégulières et des volumes sculptés par l'eau définissent les limites et caractérisent les zones et les lieux. Comme les meubles bas et les colonnes en Canneté vertical asymétrique type A qui enrichissent la salle de bain de leur personnalité délicate. Les colonnes ont une ouverture avec gorge latérale qui permet de ne pas interrompre de manière intrusive le rythme visuel de la façade, qui reste ainsi libre et équilibrée.

___ Unregelmäßige Formen und vom Wasser geformte Volumen definieren Grenzen und charakterisieren Bereiche und Orte. So wie die Unter- und Hochschränke aus asymmetrischem, vertikalem Canneté Typ A, die das Bad mit ihrer zarten Persönlichkeit bereichern. Die Hochschränke haben seitlich eine Griffmulde, so dass der optische Rhythmus der Front nicht unterbrochen wird und frei und ausgeglichen bleibt.

Las formas irregulares y los volúmenes esculpidos por el agua definen límites y caracterizan zonas y lugares. Como la base y las columnas en Canneté vertical asimétrico tipo A, que enriquecen el cuarto de baño con su delicada personalidad. Los muebles altos tienen un tirador de ranura lateral para no interrumpir intrusivamente el ritmo visual del frente, quedando así libres y equilibrados.



Nature _ Italy





M3 System _____ Matter forms emotions

_____ Top in Tekcolor Matt Terra (HDB) con vasca integrata Trip L. 50 x 31 cm è spazioso ed elegante nella sua semplicità e forma. _____ Top in Tekcolor Matt Terra (HDB) with integrated Trip W. 50 x 31 cm washbasin is spacious and elegant in its simplicity and form. _____ Top en Tekcolor Matt Terra (HDB) avec vasque intégrée Trip L. 50 x 31 cm, spacieux et élégant dans sa simplicité et sa forme. _____ Die Waschtischplatte in Tekcolor Matt Terra (HDB) mit integriertem Waschbecken Trip B. 50 x 31 cm ist geräumig und elegant in ihrer Schlichtheit und Form. _____ La encimera en Tekcolor Terra Mate (HDB) con lavabo Trip W. 50 x 31 cm integrado es espaciosa y elegante en su sencillez y forma.



C 305



M3 System _____ Matter forms emotions



_____ Dai toni delicati, le colonne con gola laterale sono caratterizzate da Cannelé tipo A (asimmetrico) in verticale. _____ In delicate tones, the tall units with side grooves are characterised by vertical Cannelé type A (asymmetrical). _____ Avec des tons délicats, les colonnes avec gorge latérale sont caractérisées par du Cannelé type A (asymétrique) vertical. _____ In zarten Tönen sind die Hochschränke mit seitlicher vertikaler Griffmulde mit Cannelé Typ A (asymmetrisch) versehen. _____ En tonos delicados, las columnas con golas laterales se caracterizan por el Cannelé vertical tipo A (asimétrico).



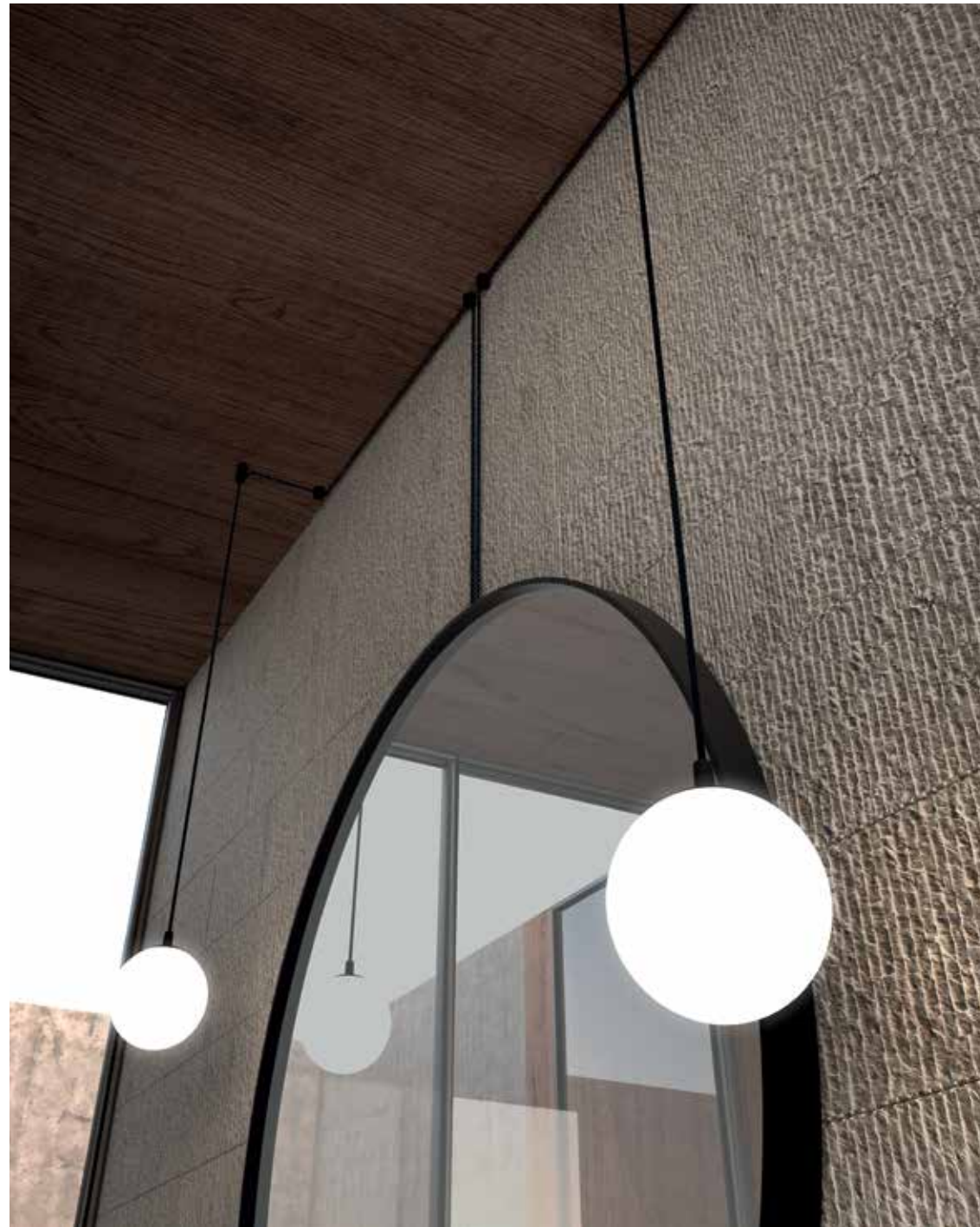

___ Uno specchio d'acqua riflette l'ambiente diffondendo la luce. In questa soluzione le lampade Globo giocano un delicato equilibrio di luci sullo specchio Spectral, protagonista a parete. Il Top Sp. 1,2 cm si presenta con doppia vasca integrata, Quadra, in Gelcolor matt Grigio Luce, a contrasto con le Colonne con anta a Telaio in alluminio Nero opaco illuminando a giorno le vetrine in un raffinato vetro stop-sol Grigio con luci a Led. I piedini Beta in metallo verniciato Nero opaco esaltano le basi che appaiono quasi sospese nel suo delicato design.

___ A water mirror reflects the environment by diffusing light. In this solution the Globo lamps play a delicate balance of lights on the Spectral mirror, the protagonist on the wall. The 1.2 cm thick Top has an integrated double basin, Quadra, in Gelcolor matt Grigio Luce, contrasting with the Columns with Frame door in matt Black aluminium, illuminating the display cabinets in refined Grey stop-sol glass with LED lights. The Beta feet in matt Black painted metal enhance the base units that appear almost suspended in their delicate design.

___ Un miroir d'eau reflète l'environnement en diffusant la lumière. Dans cette solution, les lampes Globo jouent un équilibre délicat de lumières sur le miroir Spectral, le protagoniste du mur.

Le plan de travail de 1,2 cm d'épaisseur est doté d'une double vasque intégrée, Quadra, en Gelcolor Grigio Luce mat, qui contraste avec les colonnes avec cadre en aluminium Noir mat, éclairant les vitrines en verre stop-sol Gris raffiné avec éclairage LED. Les pieds Beta en métal peint Noir mat mettent en valeur les éléments bas qui semblent presque suspendus dans leur design délicat.

___ Ein Wasserspiegel reflektiert die Umgebung, indem er das Licht streut. Bei dieser Lösung spielen die Globo-Lampen ein delikates Gleichgewicht des Lichts auf dem Spectral-Spiegel, dem Protagonisten an der Wand. Die 1,2 cm dicke Platte hat ein integriertes Doppelwaschbecken, Quadra, in Gelcolor matt Grigio Luce, das mit den Hochschränke mit Rahmentür aus mattschwarzem Aluminium kontrastiert, die die Vitrinen aus raffiniertem grauen Stop-Sol Glas mit LED-Leuchten beleuchten. Die Beta-Füße aus mattschwarz lackiertem Metall betonen die Unterschränke, die in ihrem zarten Design fast zu schweben scheinen.

___ Un espejo de agua refleja el entorno difundiendo la luz. En esta solución, las lámparas Globo juegan un delicado equilibrio de luces sobre el espejo Spectral, el protagonista de la pared. La encimera de 1,2 cm de grosor tiene una cuba lavabo doble integrada, Quadra, en Gelcolor

Grigio Luce mate, que contrasta con las columnas con puerta de marco en aluminio Negro mate, iluminando las vitrinas en refinado cristal Gris stop-sol con luces LED. Los pies Beta de metal pintado en Negro mate realzan las bases que parecen casi suspendidas en su delicado diseño.



Cava Bauxite__Otranto _ Italy





M3 System _____ Matter forms emotions

_____ La lampada Globo è alimentata dalla presa di corrente posteriore allo specchio, la configurazione del filo permette, grazie agli isolatori, di disegnare con il cavo elettrico la propria configurazione di luce sia a muro che a soffitto. _____ The Globo lamp is powered by the socket at the back of the mirror, the configuration of the wire allows, thanks to the insulators, to design with the electric cable your own light configuration both on the wall and on the ceiling. _____ La lampe Globo est alimentée par la prise située derrière le miroir, la configuration du fil permet, grâce aux isolateurs, de concevoir avec le câble électrique votre propre configuration d'éclairage aussi bien au mur qu'au plafond. _____ Die Globo-Lampe wird über die Steckdose hinter dem Spiegel mit Strom versorgt. Die Konfiguration des Kabels ermöglicht es, dank der Isolatoren, mit dem Stromkabel eine eigene Lichtkonfiguration sowohl an der Wand als auch an der Decke zu gestalten. _____ La lámpara Globo se alimenta del enchufe situado detrás del espejo, la configuración del cable permite, gracias a los aislantes, diseñar con el cable eléctrico su propia configuración de luz tanto en la pared como en el techo.









_____ Specchio Fenice, con luce perimetrale a scomparsa con tecnologia Ghost su profilo telaio che le rende invisibile quando spenta, mensola con carica smartphone wireless optional. _____ Fenice mirror, with concealed perimeter light with Ghost technology on frame profile that makes it invisible when switched off, shelf with optional wireless smartphone charger.

_____ Miroir Fenice, avec éclairage périmétrique dissimulé avec la technologie Ghost sur le profil du cadre qui le rend invisible lorsqu'il est éteint, tablette avec chargeur de smartphone sans fil en option. _____ Fenice Spiegel, mit verdeckter Beleuchtung mit Ghost-Technologie im Rahmenprofil, die im ausgeschalteten Zustand unsichtbar ist, Regal mit optionaler kabelloser Smartphone-Ladestation. _____ Espejo Fenice, con luz perimetral oculta con tecnología Ghost en el perfil del marco que la hace invisible cuando se apaga, estante con cargador inalámbrico opcional para smartphone.





___ Come la luce si infrange tra le rocce esaltando i segni del tempo sulla superficie, così si avverte la memoria di una natura che emerge negli schienali dei pensili a giorno Climb in Rovere Nero impiallacciato, il suo design pulito ed essenziale espresso nello sviluppo verticale si intreccia ai ripiani in Laccato Grigio Londra, dettagli, espressione di uno stile personale che ispira all'armonia e al benessere interiore.

___ Just as the light shatters through the rocks enhancing the signs of time on the surface, the memory of nature can be felt in the backs of the Climb open wall units in Rovere Nero veneered Wood; its clean, essential design expressed in the vertical development intertwines with the Grigio Londra Lacquered shelves, details, the expression of a personal style that inspires harmony and inner well-being.

___ De la même manière que la lumière traverse les rochers, mettant en valeur les signes du temps sur la surface, la mémoire de la nature se fait sentir dans le dos des éléments hauts ouverts Climb en placage de Rovere Nero, son design épuré et essentiel exprimé dans le développement vertical s'entrelace avec les étagères laquées Grigio Londra, détails, l'expression d'un style personnel qui inspire l'harmonie et le bien-être intérieur.

___ So wie das Licht durch die Felsen bricht und die Zeichen der Zeit auf der Oberfläche hervorhebt, so ist die Erinnerung an die Natur in den Rückwänden der offenen Hängeelemente Climb aus Furnier Rovere Nero spürbar. Ihr klares, essentielles Design, das sich in der vertikalen Entwicklung ausdrückt, verbindet sich mit den Grigio Londra lackierten Regalen und Details, dem Ausdruck eines persönlichen Stils, der Harmonie und inneres Wohlbefinden vermittelt.

___ Igual que la luz se abre paso entre las rocas, realzando los signos del tiempo en la superficie, el recuerdo de la naturaleza se percibe en los respaldos de los muebles altos Climb en chapa de Rovere Nero, su diseño limpio y esencial expresado en el desarrollo vertical se entrelaza con los estantes lacados en Grigio Londra, detalles, la expresión de un estilo personal que inspira armonía y bienestar interior.



Grotte di Pradis _F.V.G_ Italy





_____ I fianchi delle colonne con gola verticale si possono dotare di luce led esterna
_____ The Column sides with vertical groove can be fitted with an external LED light _____ Les côtés de la
colonne avec des gorges verticales peuvent être équipés d'une lumière LED externe.
_____ Die Seiten mit vertikaler Griffmulde können mit einer externen LED-Beleuchtung ausgestattet werden
_____ Los costados de las columnas con gola vertical pueden llevar una luz LED externa







_____ Top con vasca integrata Scivolo L. 70 cm in Gres Pietra Piasentina Grigia _____ Top with Scivolo integrated Washbasin W.70 cm, Gres Pietra Piasentina Grigia _____ Plan avec vasque intégrée Scivolo L.70 cm, Grès Pietra Piasentina Grigia _____ Platte mit integriertem Waschbecken Scivolo B.70 cm, Gres Pietra Piasentina Grigia _____ Encimera con lavabo integrado Scivolo L.70 cm, Gres Pietra Piasentina Grigia



_____ Il dettaglio evidenzia la generosità del cassetto attrezzato da separatori in metallo Grigio Stone. Il fondo del cassetto, impreziosito da un effetto pelle, esalta l'ordine con eleganza. Le colonne con apertura a gola verticale sono metafora di praticità e stile. _____ The detail highlights the generosity of the drawer equipped with Grigio Stone metal dividers. The bottom of the drawer, embellished with a leather effect, elegantly enhances order. The columns with vertical groove opening are a metaphor for practicality and style. _____ Le détail souligne la générosité du tiroir équipé de séparateurs métalliques Grigio Stone. Le fond du tiroir, embelli par un effet cuir, renforce l'ordre avec élégance. Les éléments hauts avec ouverture gorge verticale sont une métaphore de la praticité et du style. _____ Das Detail unterstreicht die Großzügigkeit der mit Grigio Stone Metallunterteilungen ausgestatteten Schublade. Der mit einem Ledereffekt veredelte Boden der Schublade sorgt für Ordnung und Eleganz. Die Hochschränke mit vertikaler Griffmulde sind eine Metapher für Zweckmäßigkeit und Stil. _____ El detalle destaca la generosidad del cajón equipado con separadores metálicos de Grigio Stone. El fondo del cajón, adornado con un efecto de cuero, realza el orden con elegancia. Las columnas con gola vertical son una metáfora de practicidad y estilo.



- _01 Gres Limestone Deep - TRG
- _02 Laccato Pioggia - 280
- _03 Laccato Rosso Rubino - 219
- _04 GRES Limestone Moon - TRE
- _05 Legno Rovere Nero - 06J
- _06 GRES Black Marquina Silky - TR7

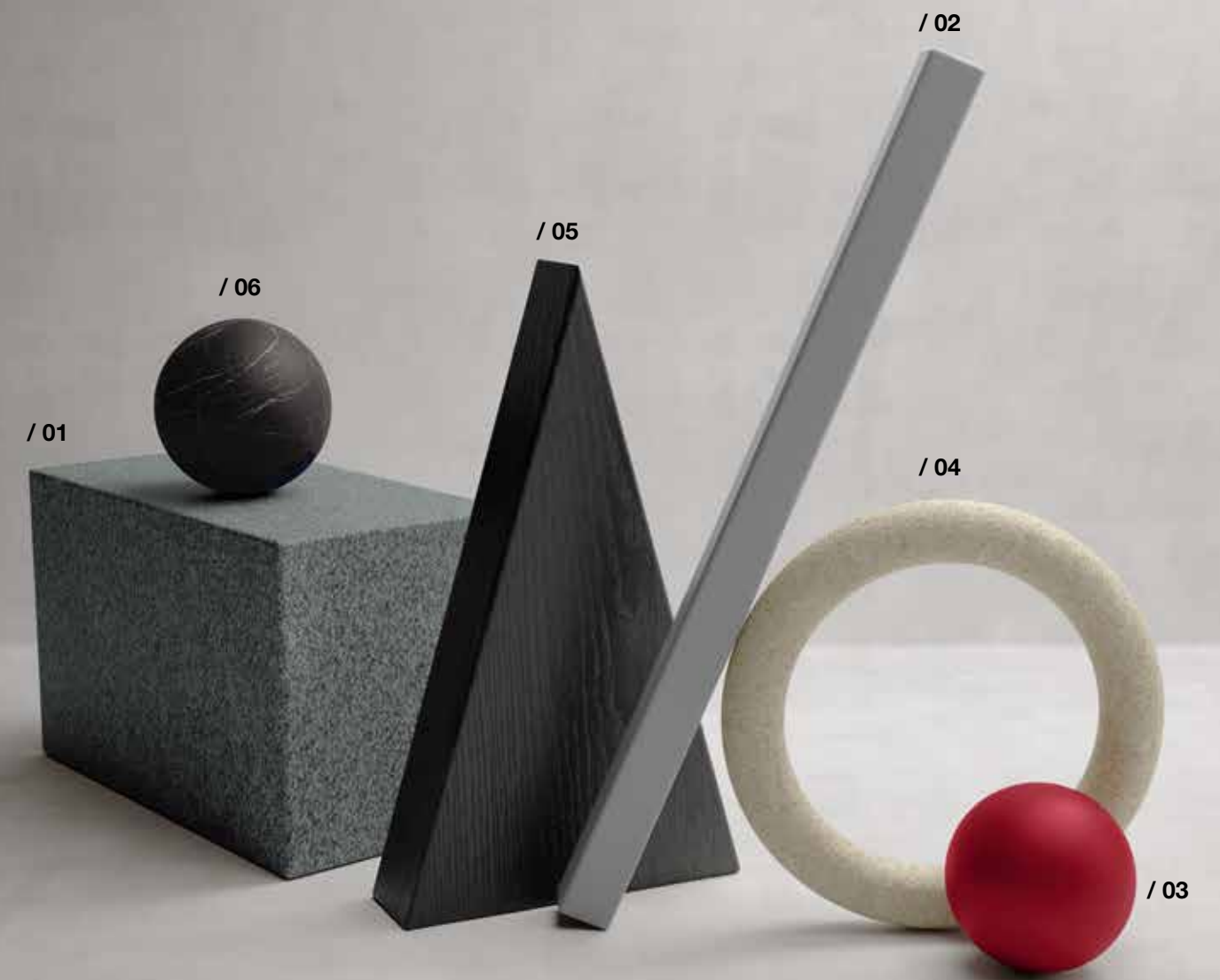



___ In un ambiente dove le linee geometriche della specchiera ottagonale Thao calamitano lo sguardo per originalità, il lavabo Ascot in Gres Pietra Piasentina Taupe, evoca alla mente l'imponenza di un monolite che accoglie generoso lo scorrere dell'acqua, elemento naturale per eccellenza. Le colonne in legno impiallacciato Rovere Sabbia che lo circondano, vibrano di calde energie che donano armonia e creano un perfetto equilibrio tra essenza naturale e solidità.

___ In an environment where the geometric lines of the octagonal Thao mirror attract the eye with its originality, the Ascot washbasin in Gres Pietra Piasentina Taupe evokes the grandeur of a monolith that generously welcomes the flow of water, the natural element par excellence. The columns in Rovere Sabbia veneered wood surrounding it vibrate with warm energies that give harmony and create a perfect balance between natural essence and solidity.

___ Dans un environnement où les lignes géométriques du miroir octogonal Thao attirent l'oeil pour son originalité, la vasque Ascot en Grès Pietra Piasentina Taupe évoque la grandeur d'un monolithe qui accueille généreusement le flux de l'eau, l'élément naturel par excellence. Les colonnes en plaqués Rovere Sabbia

qui l'entourent vibrent d'énergies chaudes qui donnent de l'harmonie et créent un équilibre parfait entre essence naturelle et solidité.

___ In einer Umgebung, in der die geometrischen Linien des achteckigen Spiegels Thao mit ihrer Originalität die Blicke auf sich ziehen, erinnert der Waschtisch Ascot aus Gres Pietra Piasentina Taupe an die Erhabenheit eines Monolithen, der den Fluss des Wassers, des natürlichen Elements schlechthin, großzügig aufnimmt. Die Hochschränke aus Furnier Rovere Sabbia, die sie umgeben, vibrieren mit warmen Energien, die Harmonie verleihen und ein perfektes Gleichgewicht zwischen natürlicher Essenz und Solidität schaffen.

___ En un ambiente donde las líneas geométricas del espejo octogonal Thao atraen la mirada con su originalidad, la cuba Ascot de Gres Pietra Piasentina Taupe evoca la grandeza de un monolito que acoge generosamente el flujo del agua, el elemento natural por excelencia. Las columnas de chapa Rovere Sabbia que lo rodean vibran con energías cálidas que dan armonía y crean un equilibrio perfecto entre la esencia natural y la solidez.



Cala Diamante _Sardegna _ Italy





_____ Colonne H. 250 cm in legno impiallacciato Rovere Sabbia con apertura a gola verticale.
 _____ Columns h. 250 cm in Rovere Sabbia veneered Wood with vertical groove opening. _____
 Colonne H. 250 cm plaquées Rovere Sabbia avec ouverture gorge verticale. _____ Hochschränke
 H. 250 cm aus Furnier Rovere Sabbia mit vertikaler Griffmulde. _____ Columnas H. 250 cm con
 enchapado en Madera Rovere Sabbia con gola vertical.



_____ Lo specchio Thao ottagonale, dal telaio in alluminio verniciato Nero opaco è disponibile in tre varianti: privo di illuminazione, dotato di tre lampade superiori, o con tre lampade superiori e retroilluminazione perimetrale comandabili tramite interruttori touch.

_____ The octagonal Thao mirror, with its matt Black painted aluminium frame, is available in three variants: without lighting, with three top lamps, or with three top lamps and perimeter backlighting controlled by touch switches. _____ Le miroir octogonal Thao, avec son cadre en aluminium peint en Noir mat, est disponible en trois variantes: sans éclairage, avec trois lampes supérieures, ou avec trois lampes supérieures et un rétro-éclairage périphérique commandé par des interrupteurs tactiles. _____ Der achteckige Thao-Spiegel mit seinem mattschwarz lackierten Aluminiumrahmen ist in drei Varianten erhältlich: ohne Beleuchtung, mit drei Aufsatzleuchten oder mit drei Aufsatzleuchten und einer über Berührungsschalter gesteuerten Umrandungshinterleuchtung.

_____ El espejo octogonal Thao, con su marco de aluminio pintado en Negro opaco, está disponible en tres variantes: sin iluminación, con tres lámparas superiores, o con tres lámparas superiores y retro-iluminación perimetral controlada por interruptores táctiles.

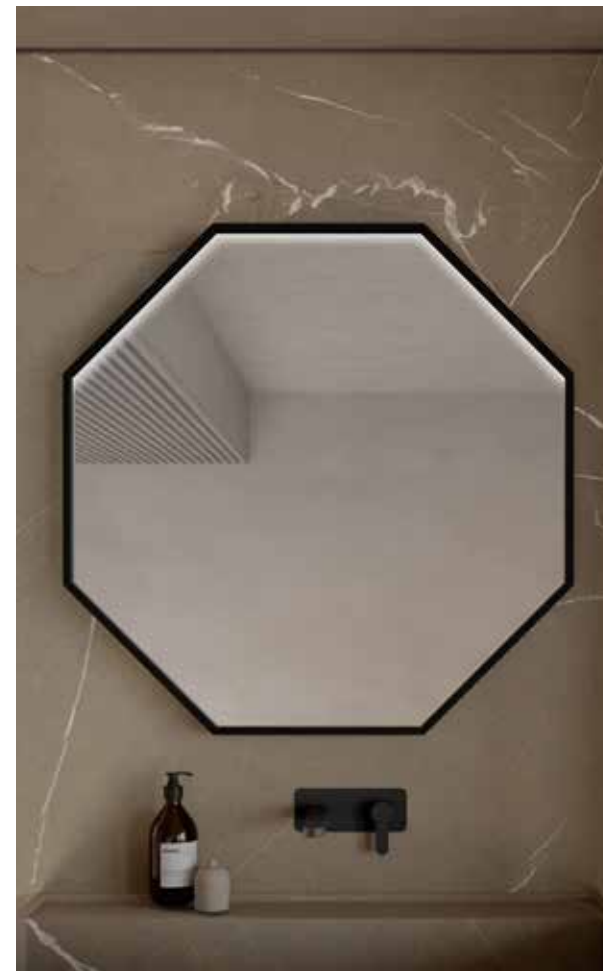
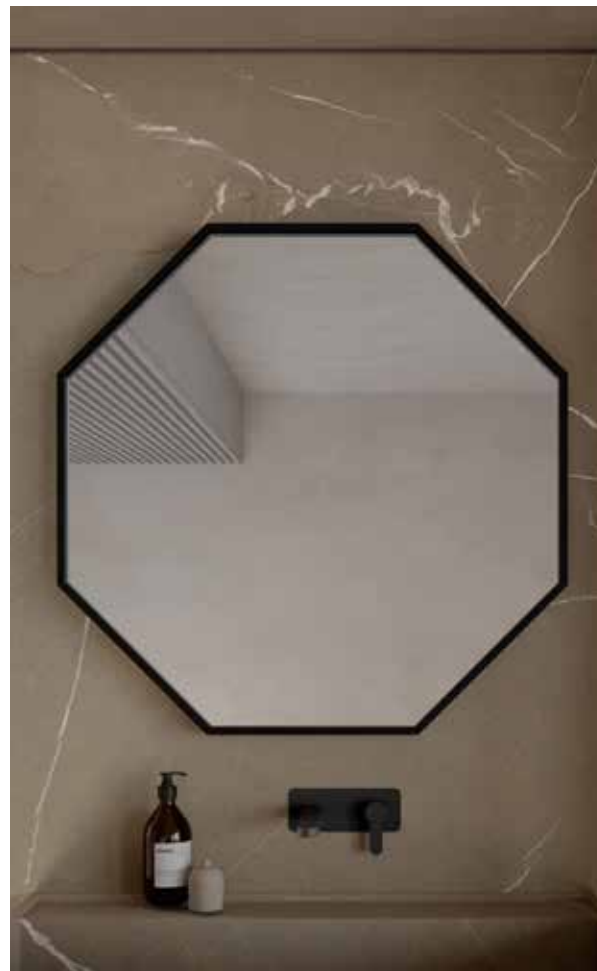



____ Nel dettaglio brillano gli interruttori con touch a sfioro per accensione-spegnimento, cambio colore e dimmerazione di intensità di luce. Il Lavabo Monolite Ascot H. 29,7 - L. 90 in Gres Pietra Piasentina Taupè dona un piacevole tocco materico all'ambiente. ____ The touch-sensitive switches for switching on/off, changing colour and dimming the light intensity are brightly displayed in the detail. The Ascot washbasin H. 29,7 - W 90 in Gres Pietra Piasentina Taupè gives a pleasant material touch to the room. ____ Dans le détail brillent les interrupteurs tactiles qui permettent d'allumer et d'éteindre, de changer de couleur et de varier l'intensité lumineuse. La vasque Ascot H. 29,7 - L 90 en Grès Pietra Piasentina Taupè donne une agréable touche matérielle à la pièce. ____ Die berührungsempfindlichen Schalter zum Ein- und Ausschalten, Ändern der Farbe und Dimmen der Lichtintensität strahlen im Detail. Das Waschbecken Ascot H. 29,7 - B 90 aus Gres Pietra Piasentina Taupè verleiht dem Raum eine angenehme materielle Note. ____ Los interruptores sensibles al tacto para el encendido/apagado, el cambio de color y la regulación de la intensidad de la luz brillan en el detalle. La cuba Ascot H. 29,7 - W 90 en Gres Pietra Piasentina Taupè da un agradable toque material a la habitación.





___ L'architettura di questa composizione esprime l'essenza della leggerezza. La trasparenza del vetro fumè delle colonne ad anta Telaio in alluminio verniciato Nero, concede allo sguardo di intravedere il suo contenuto, ed esaltarlo con una luce interna. I pensili a giorno Cleo abbinati, con schienale in legno impiallacciato Eucalipto affumicato, danno vita ad un elegante contrasto di superfici materiche, di pieni e vuoti.

___ The architecture of this composition expresses the essence of lightness. The transparency of the smoked glass of the columns with Black painted aluminium doors allows the eye to catch a glimpse of its contents, and enhances them with an internal light. The matching Cleo open wall units, with backs in Eucalipto affumicato veneer, create an elegant contrast of material surfaces, of full and empty volumes.

___ L'architecture de cette composition exprime l'essence de la légèreté. La transparence du verre fumé des colonnes avec portes en aluminium laqué Noir laisse entrevoir son contenu et le met en valeur par un éclairage interne. Les éléments hauts ouverts Cleo assortis, dont le dos est plaqué en Eucalipto affumicato, créent un contraste élégant entre les surfaces matérielles, les pleins et les vides.

___ Die Architektur dieser Komposition drückt die Essenz der Leichtigkeit aus. Die Transparenz des Rauchglases der Hochschränke mit den schwarz lackierten Aluminiumtüren gibt den Blick auf den Inhalt frei und unterstreicht ihn mit einer Innenbeleuchtung. Die dazu passenden offenen Hängeschränke Cleo mit Rückwänden aus Eucalipto affumicato Furnier bilden einen eleganten Kontrast von Materialoberflächen, Fülle und Leere.

___ La arquitectura de esta composición expresa la esencia de la ligereza. La transparencia del cristal ahumado de las columnas con puertas de aluminio pintado en Negro permite vislumbrar su contenido y lo realza con una luz interior. Los colgantes abiertos Cleo, con respaldos en chapa de Eucalipto affumicato, crean un elegante contraste de superficies materiales, llenos y vacíos.



Land Art _Valle Vecchia_ Italy







_____ Gli spaziosi cassetti sono attrezzati con separatori in metallo in tinta con le sponde in metallo Grigio Stone. Il fondo del cassetto è affinato da un effetto pelle. _____ The spacious drawers are equipped with metal dividers to match the Grigio Stone metal sides. The bottom of the drawer is refined with a leather effect. _____ Les tiroirs spacieux sont équipés de séparateurs métalliques assortis aux côtés métalliques Grigio Stone. Le fond du tiroir est affiné par un effet cuir. _____ Die geräumigen Schubladen sind mit Metallunterteilungen ausgestattet, die zu den Grigio Stone Metallseiten passen. Der Boden der Schublade ist mit einer Leder-Effekt veredelt. _____ Los amplios cajones están equipados con separadores metálicos a juego con los laterales metálicos de color Grigio Stone. El fondo del cajón está refinado con un efecto de cuero.



C 309



M3 System _____ **Matter forms emotions**

_____ Top con vasca integrata Prisma L. 70 cm in Gres Sahara Noir Silky _____ Top with Prisma integrated Washbasin L.70 cm, Gres Sahara Noir Silky _____ Plan avec vasque intégrée Prisma L.70 cm, Grès Sahara Noir Silky _____ Platte mit integriertem Waschbecken Prisma B.70 cm, Gres Sahara Noir Silky _____ Encimera con lavabo integrado Prisma L.70 cm, Gres Sahara Noir Silky







_____ Pensile a giorno Cleo con fianco metallo verniciato Nero,
 schienale in legno impiallacciato Eucalipto affumicato e ripiani Laccato Nero opaco
 _____ Cleo Open Wall Unit Nero painted metal side panel, back panel
 in Eucalipto affumicato veneered Wood and matt Nero lacquered shelves
 _____ Élément haut ouverts Cleo avec joue en métal peint Nero,
 panneau de finition arrière plaqué Eucalipto affumicato et tablettes laquées Nero mat
 _____ Offene Hängeschränke Cleo mit Nero Metallseitenwand, Rückenteil
 aus Furnier Eucalipto affumicato und Ablagefächern in Nero matt lackiert.
 _____ Colgantes abiertos Cleo con costado en metal pintado Nero,
 respaldo en enchapado Eucalipto affumicato y estantes lacados Nero opaco.

M3 System _____ Matter forms emotions



Materials Suggestions | D |

- _01 Legno Eucalipto - 01A
- _02 Legno Rovere Moka - 06H
- _03 GRES Metal Grey - TRD
- _04 Gres Pietra Piasentina Taupè - TQQ
- _05 Gres Pietra Piasentina Grigia - TQP
- _06 Laccato Aragosta - 277





___ Attraverso la forma la nostra visione cambia prospettiva, l'alternarsi di pieni e vuoti di una parete invita alla scoperta e a fare luce su ciò che è utile illuminare, la funzione dell'arte e del design che stimola a creare emozioni e a ricercare la bellezza in ogni dettaglio. Il lavabo tuttofuori Blade 06 (Ø40) in Ceramica Cenere, abbinato alle specchiere Aurora retroilluminate su telaio in alluminio a 45°, catturano lo sguardo e si fanno protagonisti di un progetto vocato al design, la simmetria e al suo contrasto.

___ Through the shape our perspective changes, the succession of full and empty spaces on a wall calls for discovery and to shed light on what is useful to illuminate, the purpose of art and design that stimulates to create emotions and to search for beauty in every detail. The Blade 06 sit-on washbasin (Ø40) in Cenere Ceramic, combined with the Aurora backlit mirrors on a 45° aluminium frame, catch the eye and become the protagonists of a project devoted to design, symmetry and contrast.

___ À travers la forme, notre vision change de perspective, l'alternance de pleins et de vides sur un mur invite à la découverte et à la mise en lumière de ce qui est utile pour éclairer, la fonction de l'art et du design qui stimule à créer des émotions et à rechercher la beauté dans chaque détail. La vasque Blade 06 (Ø40) en Céramique Cenere, associé aux

miroirs Aurora rétroéclairés sur un cadre en aluminium à 45°, attirent le regard et deviennent les protagonistes d'un projet consacré au design, à la symétrie et au contraste.

___ Durch die Form ändert sich unsere Sichtweise, der Wechsel von vollen und leeren Flächen auf einer Wand lädt zur Entdeckung ein und beleuchtet, was nützlich ist, die Funktion von Kunst und Design, die dazu anregt, Emotionen zu erzeugen und nach Schönheit in jedem Detail zu suchen. Der Aufsatzwaschbecken Blade 06 (Ø40) aus Keramik Cenere in Kombination mit den hinterleuchteten Aurora-Spiegeln, die auf einem 45°-Aluminiumrahmen sind, ziehen die Blicke auf sich und werden zu Protagonisten eines Projekts, das sich dem Design, der Symmetrie und dem Kontrast widmet.

___ A través de la forma nuestra visión cambia de perspectiva, la alternancia de espacios llenos y vacíos en una pared invita al descubrimiento y a arrojar luz sobre lo que sirve para iluminar, la función del arte y el diseño que estimula a crear emociones y a buscar la belleza en cada detalle. El lavabo externo Blade 06 (Ø40) de Ceramica Cenere, combinado con los espejos Aurora retro-iluminados sobre un marco de aluminio a 45°, llaman la atención y se convierten en los protagonistas de un proyecto dedicado al diseño, la simetría y el contraste.

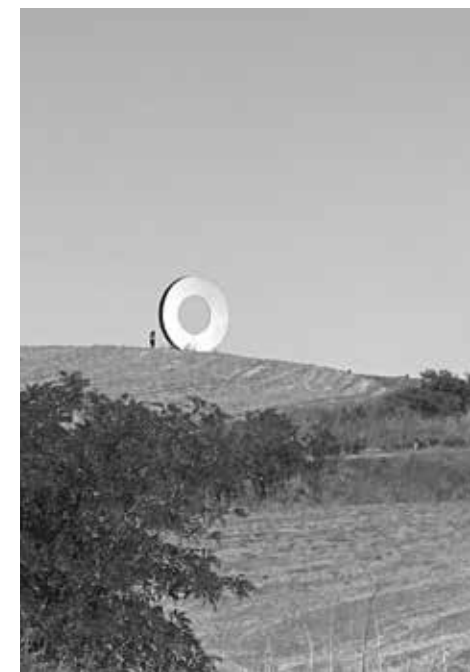

Land Art _ Mauro Staccioli
Colle Val d'Elsa_Italy





_____ Dettaglio su cerniera anta a telaio in alluminio verniciato Creta opaco con pannello vetro Stop-sol Grigio abbinato al portasalviette Look. _____ Detail of hinge for aluminium frame door painted matt Creta with Grigio Stop-sol glass panel combined with towel rack Look. _____ Détail de la charnière pour porte à cadre en aluminium peint Creta mat avec panneau en verre Stop-sol Grigio combiné avec porte-serviettes Look. _____ Detail des Scharniers für Aluminiumrahmentür lackiert matt Creta mit Stop-sol Glas Grigio kombiniert mit Handtuchhalter Look. _____ Detalle en la bisagra de la puerta marco de aluminio pintado Creta opaco con panel de cristal Stop-sol Grigio combinado con el seca-toallas Look.







M3 System _____ Matter forms emotions

_____ Colonne H. 250 con vano a giorno in legno impiallacciato Rovere Moka e frontali laccati Creta metallizzato opaco, vano a giorno disponibile anche con illuminazione superiore. _____ Columns H. 250 with open compartment in Rovere Moka veneered wood and fronts in matt metallised Creta lacquer, open compartment also available with upper lighting. _____ Colonne H. 250 avec compartiment ouvert en bois plaqué en Rovere Moka et façades en laque Creta métallisée mate, compartiment ouvert également disponible avec éclairage supérieur. _____ Hochschränke H. 250 mit offenem Fach in Rovere Moka furniert und Fronten in Creta Metalliclack, offenes Fach auch mit oberer Beleuchtung erhältlich. _____ Columnas H. 250 con compartimento abierto en madera chapada en Rovere Moka y frentes en laca Creta metalizado opaco, compartimento abierto también disponible con iluminación superior.





___ È affascinante soffermarsi ad osservare l'acqua mentre, scorrendo, riflette la luce delle superfici che la cullano. Si circondano dello stesso piacevole senso di benessere le Colonne Anta Telaio Alluminio verniciato Nero con vetro fumè esaltate dall'illuminazione Led interna.

___ It is fascinating to stop and observe the water as it flows and reflects the light from the surfaces that cradle it. The same pleasant sense of wellbeing surrounds the Columns with Black painted Aluminium Frame with smoked glass, enhanced by internal LED lighting.

___ Il est fascinant de s'arrêter et d'observer l'eau qui coule et reflète la lumière des surfaces qui l'entourent. La même agréable sensation de bien-être entoure les colonnes à cadre en aluminium Noir peint avec du verre fumé, agrémentées d'un éclairage interne à LED.

___ Es ist faszinierend, innezuhalten und das Wasser zu beobachten, wie es fließt und das Licht von den Oberflächen, die es umschließen, reflektiert. Das gleiche angenehme Gefühl des Wohlbefindens umgibt auch die Hochschränke mit schwarz lackiertem Aluminiumrahmen und Rauchglas, die durch eine LED-Innenbeleuchtung verstärkt werden.

___ Es fascinante detenerse a observar el agua mientras fluye y refleja la luz de las superficies que la acunan. La misma agradable sensación de bienestar rodea a las Columnas con Marco de Aluminio pintado Negro con cristal ahumado, realizadas por la iluminación interna de LED.



Cascade Platische _ Italy



C 311



M3 System _____ **Matter forms emotions**

_____ Lo specchio contenitore Tableau, in metallo verniciato Nero opaco, custodisce uno schienale in legno impiallacciato Rovere Cenere sapientemente illuminato dalla Lampada Short mini. Il Top Sp. 6 cm con vasca integrata Prisma L. 60 cm Gres Pietra Grey _____ The Tableau container mirror, in matt Black painted metal, houses a back panel in Rovere Cenere veneer wood, cleverly lit by the Short mini lamp. Top Th. 6 cm with Prisma integrated washbasin W. 60 cm in Gres Pietra Grey. _____ L'armoire miroir Tableau, en métal peint Noir mat, contient un panneau arrière en bois plaqué Rovere Cenere, astucieusement éclairé par l'applique Short mini. Plan Ép. 6 cm avec vasque intégrée Prisma L. 60 cm en Grès Pietra Grey. _____ Der Tableau Spiegelschrank aus mattschwarz lackiertem Metall beherbergt eine Rückwand aus Rovere Cenere Furnier, die von der Lampe Short mini geschickt beleuchtet wird. Platte St. 6 cm mit integriertem Waschbecken Prisma B. 60 cm in Gres Pietra Grey. _____ El espejo contenedor Tableau, de metal pintado en Negro mate, alberga un panel trasero de madera chapada de Rovere Cenere, ingeniosamente iluminado por la lámpara Short mini. Encimera Esp. 6 cm con lavabo integrado Prisma L. 60 cm está fabricada en Gres Pietra Grey.





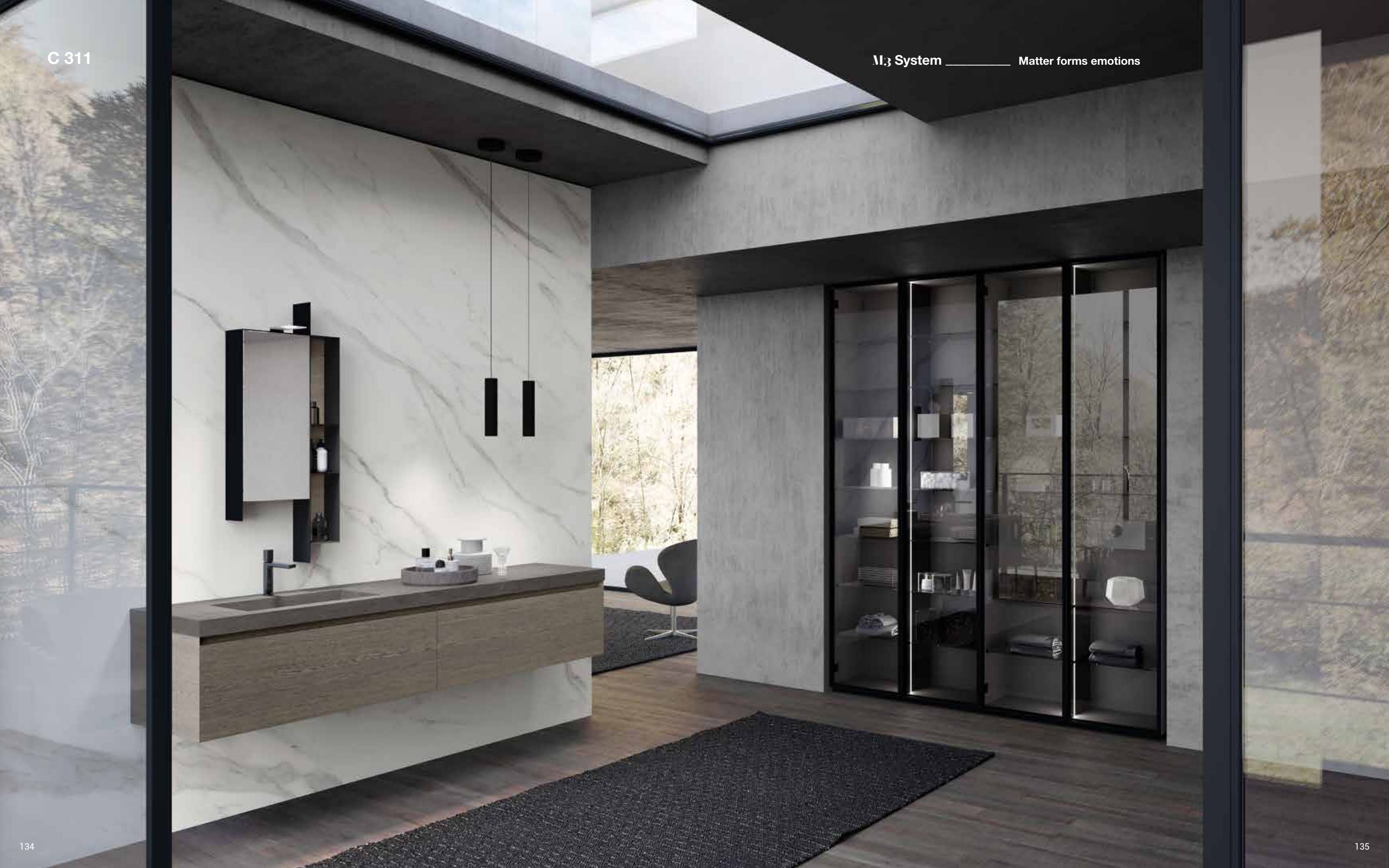



Materials Suggestions | E |

- _01 Gres Pietra Grey - TQU
- _02 Legno Rovere Cenere - 06D
- _03 Gres Avenue Plumb - TRB
- _04 Legno Rovere Carbone - 06G
- _05 Gres Aosta Green marble lucido - TR4
- _06 Laccato Verde Comodoro - 2FG

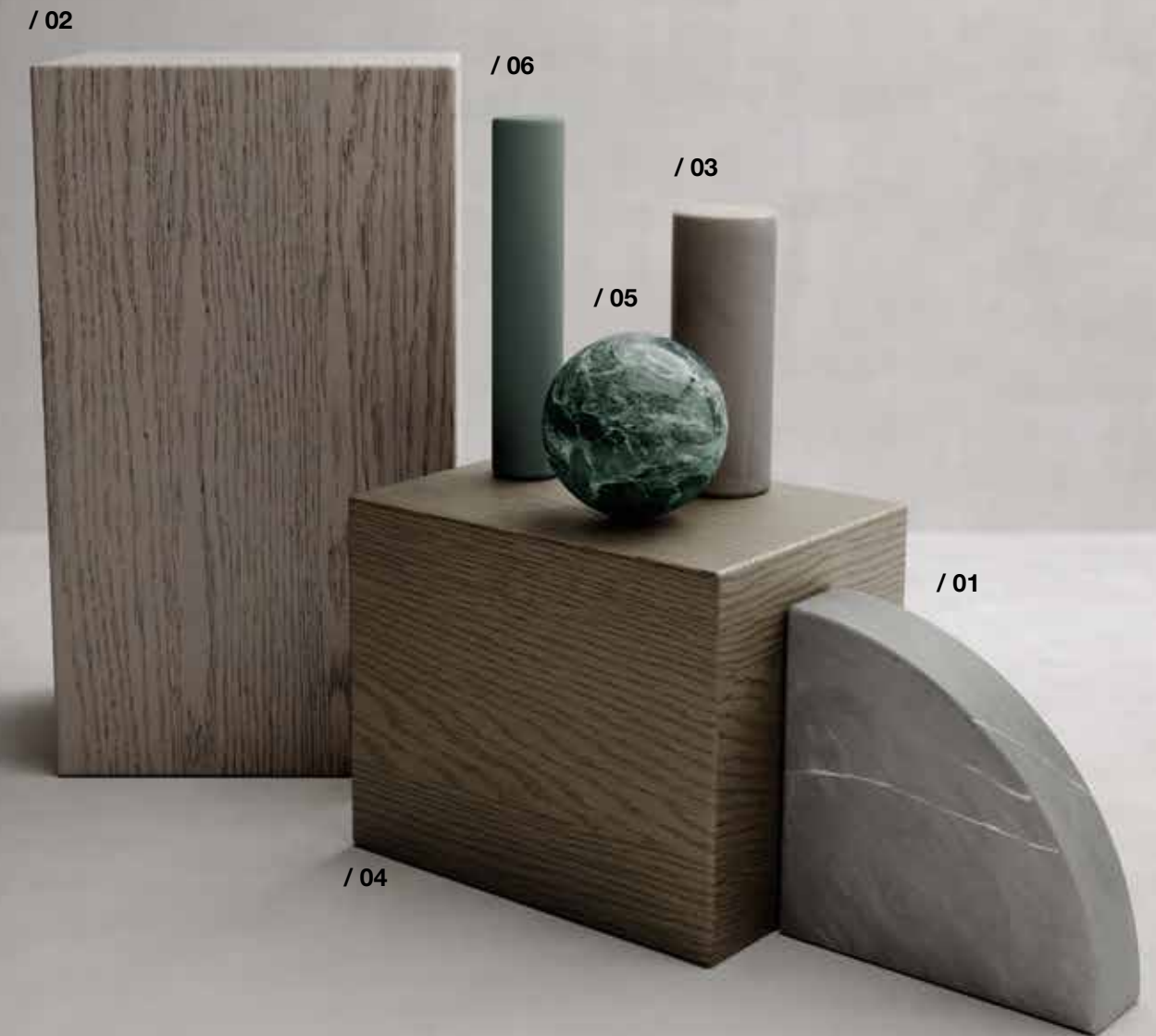



___ Un maestoso Top in Dekorativo 3D Eucalipto Lab Affumicato si presenta al centro della composizione, come solida base d'appoggio del lavabo Tutto Fuori Smart B05 che si erge sinuoso nella sua delicata Ceramica Bianca opaca, simbolo di purezza, fonte preziosa della cura e del benessere personale. Le linee verticali dei pensili, fondano le loro radici sul top, un piccolo vano a giorno illuminabile, esalta l'incontro creando una contrapposizione armonica di linee semplici e pulite.

___ A majestic top in Dekorativo 3D Eucalipto Lab Affumicato is at the centre of the composition, as a solid base for the Smart B05 sit-on washbasin, which rises sinuously in its delicate matt White Ceramic, a symbol of purity, a precious source of personal care and well-being. The vertical lines of the wall units are rooted in the top, a small open compartment that can be illuminated, enhancing the meeting by creating a harmonious contrast of simple and clean lines.

___ Un majestueux plan en Dekorativo 3D Eucalipto Lab Affumicato est au centre de la composition, comme une base solide pour la vasque à poser Smart B05, qui s'élève sinueusement dans sa délicate Céramique Blanche mate, symbole de pureté, source précieuse de soin personnel et de bien-être. Les lignes

verticales des éléments hauts s'enracinent dans le plan, un petit compartiment ouvert qui peut être éclairé, mettant en valeur la rencontre en créant un contraste harmonieux de lignes simples et épurées.

___ Im Zentrum der Komposition steht eine majestätische Platte aus Dekorativo 3D Eucalipto Lab Affumicato, die als solide Basis für den Aufsatzwaschtisch Smart B05 dient, der sich in seiner zarten matten weißen Keramik geschmeidig erhebt, ein Symbol der Reinheit, eine wertvolle Quelle der Körperpflege und des Wohlbefindens. Die vertikalen Linien der Hängeschränke sind in der Platte verwurzelt, einem kleinen offenen Fach, das beleuchtet werden kann und die Begegnung durch einen harmonischen Kontrast von einfachen und klaren Linien aufwertet.

___ Una majestuosa Encimera de Dekorativo 3D Eucalipto Lab Affumicato está en el centro de la composición, como sólida base del lavabo externo Smart B05, que se eleva sinuosamente en su delicada Cerámica Blanca mate, símbolo de pureza, fuente preciosa de cuidado personal y bienestar. Las líneas verticales de los colgantes se enraizan en la encimera, un pequeño compartimento abierto que puede iluminarse, realzando el encuentro al crear un armonioso contraste de líneas simples y limpias.



Piscine naturali_Due Sorelle Otranto _Puglia _ Italy





_____ Lavabo Tutto Fuori Smart B05 - L.55 P. 45 cm in Ceramica Bianco Opaco in appoggio su Top Sp. 10 cm in Dekorativo 3D Eucalipto Lab Affumicato _____ Smart B05 Sit-on washbasin - L.55 D. 45 cm in matt White Ceramic placed on a 10-cm-thick Top in Dekorativo 3D Eucalipto Lab Affumicato. _____ Vasque à poser Smart B05 - L. 55 cm P. 45 cm Céramique Blanche opaque sur un plan de 10 cm d'épaisseur en Dekorativo 3D Eucalipto Lab Affumicato. _____ Aufsatzwaschbecken Smart B05 - B.55 T. 45 cm aus opaker weißer Keramik auf einer 10 cm dicken Platte aus Dekorativo 3D Eucalipto Lab Affumicato. _____ Lavabo externo Smart B05 - L. .55 P. 45 cm en Cerámica Blanca Mate apoyado sobre Encimera Esp. 10 cm en Dekorativo 3D Eucaipto Lab Affumicato.









_____ La lampada Stelo è alimentata dalla presa di corrente posteriore allo specchio, la configurazione del filo permette, grazie agli isolatori, di disegnare con il cavo elettrico la propria configurazione di luce sia a muro che a soffitto. Pagina precedente. La lampada Thin è modulare su tutta la larghezza dello specchio. _____ The Stelo lamp is powered by the socket at the back of the mirror, the configuration of the wire allows, thanks to the insulators, to design with the electrical cable its own light configuration both on the wall and on the ceiling. Previous page. The Thin lamp is modular across the width of the mirror. _____ L'applique Stelo est alimentée par la prise située à l'arrière du miroir, la configuration du fil permet, grâce aux isolateurs, de concevoir avec le câble électrique sa propre configuration lumineuse aussi bien au mur qu'au plafond. Page précédente. L'applique Thin est modulable sur la largeur du miroir. _____ Die Stelo-Lampe wird über die Steckdose auf der Rückseite des Spiegels mit Strom versorgt. Die Konfiguration des Kabels ermöglicht es, dank der Isolatoren, mit dem Stromkabel eine eigene Lichtkonfiguration sowohl an der Wand als auch an der Decke zu gestalten. Vorherige Seite. Die Lampe Thin ist modular über die gesamte Breite des Spiegels aufgebaut. _____ La lámpara Stelo se alimenta del enchufe situado en la parte posterior del espejo, la configuración del cable permite, gracias a los aislantes, diseñar con el cable eléctrico su propia configuración de luz tanto en la pared como en el techo. Página anterior. La lámpara Thin es modular a todo lo ancho del espejo.

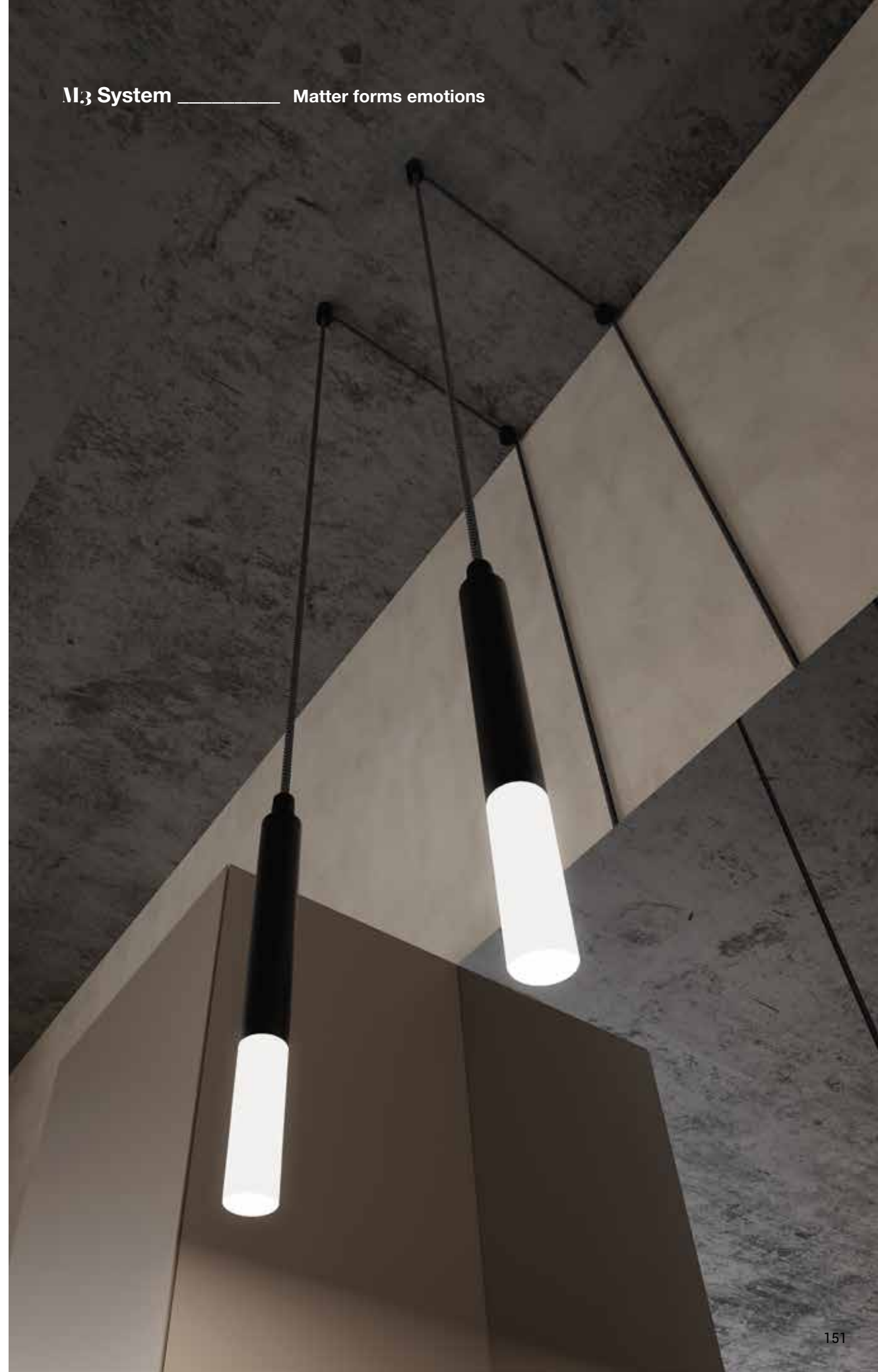

- _01 Dekorativo 3D Eucalipto Lab Affumicato - 1E2
- _02 Dekorativo 3D Castagno Scuro - 1C3
- _03 Gres Shara Noir Lucido - TQJ
- _04 Laccato Roccia - 2CE
- _05 HPL Pulpis Scuro - TKJ
- _06 Gres Fokos Rena - TQ2





___ Terra e cielo si incontrano e si specchiano in un bacino d'acqua naturale, generoso e rigenerante luogo di connessione. Così il lavabo in Gres Limestone Deep accompagna come la notte il giorno l'originale forma della Specchiera Hexagon Plus, dotata di lampada Thin a Led opzionale e impreziosita dal telaio, in metallo Carbone opaco, la sua luce la fa risplendere riflettendosi sulla superficie lunare del piano in Gres.

___ Earth and sky meet and are reflected in a natural water basin, a generous and regenerating place of connection. This is how the Gres Limestone Deep washbasin accompanies the original shape of the Hexagon Plus mirror, equipped with the optional Thin LED lamp and embellished by the matt Carbone painted metal frame, whose light shines as it reflects off the lunar surface of the top in Gres.

___ La terre et le ciel se rencontrent et se reflètent dans un bassin d'eau naturel, un lieu de connexion généreux et régénérateur. C'est ainsi que le lavabo en Grès Limestone Deep accompagne la forme originale du miroir Hexagon Plus, équipé de l'applique Thin LED en option et embelli par le cadre métallique en Carbone mat, dont la lumière brille en se reflétant sur la surface lunaire du plan en grès.

___ Erde und Himmel treffen aufeinander und spiegeln sich in einem natürlichen Wasserbecken, einem großzügigen und regenerierenden Ort der Verbindung. So passt das Waschbecken aus Gres Limestone Deep zur originellen Form des Spiegels Hexagon Plus, der mit der optionalen Lampe Thin mit LED ausgestattet ist und durch den Metallrahmen matt Carbone lackiert veredelt wird, dessen Licht von der Mondoberfläche der Platte aus Gres reflektiert wird.

___ La tierra y el cielo se encuentran y se reflejan en una cuenca de agua natural, un lugar de conexión generoso y regenerador. Así es como el lavabo de Gres Limestone Deep acompaña la forma original del espejo Hexagon Plus, equipado con la lámpara Thin LED opcional y embellecido por el marco metálico lacado Carbone opaco, cuya luz brilla al reflejarse en la superficie lunar de la encimera de gres.



Lago Cave del Predil _Tarvisio
F.V.G_ Italy



_____ Lavabo Ascot H. 39,7 L. 90 cm in Gres Limestone Deep. _____ Ascot Washbasin H. 39,7 L. 90 cm in Gres Limestone Deep. _____ Vasque Ascot H. 39,7 L. 90 cm en Grès Limestone Deep. _____ Waschbecken Ascot H. 39,7 B. 90 cm in Gres Limestone Deep. _____ Lavabo Ascot H. 39,7 L. 90 cm en Gres Limestone Deep.





_____ Dettagli attrezzatura interna modulare in metallo grigio Stone con fondo effetto pelle. Pagina precedente_ Mensole Hexagon Plus in decorativo 3D Noce rigato Grigio con telaio in metallo verniciato carbone opaco _____ Details of modular interior equipment Grigio Stone painted metal with leather-effect bottom. Previous page Hexagon Plus shelves in Dekorativo 3D Noce Rigato Grigio with matt Carbone painted metal frame _____ Détails de l'équipement intérieur modulaire en métal Grigio Stone avec fond effet cuir. Page précédente_ Étagères Hexagon Plus en Dekorativo 3D Noce Rigato Grigio avec cadre en métal peint Carbone mat _____ Details der modularen Innenausstattung aus Grigio Stone Metall mit Boden in Ledereffekt. Vorherige Seite_ Wandborde Hexagon Plus in Dekorativo 3D Noce Rigato Grigio mit matt Carbone lackiertem Metallrahmen _____ Detalles del equipamiento interior modular en metal Grigio Stone con fondo efecto cuero. Página anterior_ Estantes Hexagon Plus en Dekorativo 3D Noce Rigato Grigio con marco metálico pintado Carbone mate.





___ Ogni elemento naturale ci ispira nella progettazione di forme e superfici, le tracce lasciate dalla sabbia nel ritirarsi delle onde ci suggeriscono come la natura sia flessibile e versatile seguendo il suo flusso. Così M3 System si adegua ad arredare anche piccoli spazi, ottimizzando ogni volume in funzione del vostro benessere, senza mai rinunciare alla bellezza, lo si percepisce dai dettagli che compongono il progetto nel quale forma e funzionalità divengono il vostro, unico ed esclusivo.

___ Every natural element inspires us in the design of forms and surfaces, the traces left by the sand in the retreat of the waves suggest how flexible and versatile nature is in following its flow. This is how the M3 System adapts to decorate even small spaces, optimising every volume for your well-being, without ever renouncing beauty. This can be perceived in the details that compose the design in which form and function become yours, unique and exclusive.

___ Chaque élément naturel nous inspire dans la conception des formes et des surfaces, les traces laissées par le sable dans le retrait des vagues suggèrent à quel point la nature est flexible et versatile en suivant son cours. C'est ainsi que M3 System s'adapte

à l'ameublement des espaces, même petits, en optimisant chaque volume pour votre bien-être, sans jamais renoncer à la beauté, perceptible dans les détails qui composent le design où forme et fonction deviennent vôtres, uniques et exclusives.

___ Jedes natürliche Element inspiriert uns bei der Gestaltung von Formen und Oberflächen, die Spuren, die der Sand auf dem Rückzug der Wellen hinterlässt, zeigen, wie flexibel und vielseitig die Natur ihrem Lauf folgt. So passt sich M3 System an die Einrichtung auch kleiner Räume an und optimiert jedes Volumen für Ihr Wohlbefinden, ohne jemals auf Schönheit zu verzichten, die sich in den Details des Designs widerspiegelt, in dem Form und Funktion zu den Ihren werden, einzigartig und exklusiv.

___ Todos los elementos naturales nos inspiran en el diseño de formas y superficies, las huellas que deja la arena en el retroceso de las olas sugieren lo flexible y versátil que es la naturaleza al seguir su flujo. Así es como M3 System se adapta a amueblar incluso espacios pequeños, optimizando cada volumen para su bienestar, sin renunciar nunca a la belleza. Esto se percibe en los detalles que componen el diseño en el que forma y función se convierten en algo suyo, único y exclusivo.



Litorale Grado _F.V.G._ Italy





_____ Il lavamani Theo L. 60 cm in Tecnoril Bianco Opaco poggia su una base in Dekorativo 3D Noce rigato chiaro _____ The Theo hand-rinse W.60 cm in Tecnoril Bianco Matt rests on a base unit with door in Dekorativo 3D Noce rigato chiaro _____ Le Lave-mains Theo L.60 cm en Tecnoril Bianco Mat repose sur un élément bas avec porte en Dekorativo 3D Noce rigato chiaro _____ Das Theo Hand-Waschbecken B. 60 cm aus Tecnoril Bianco Matt ruht auf einem Unterschrank mit Tür aus Dekorativo 3D Noce rigato chiaro _____ El Lavamanos Theo L. 60 cm en Tecnoril Bianco Opaco descansa sobre una base con puerta en Dekorativo 3D Noce rigato chiaro



_____ Lo specchio Pollux è dotato di tecnologia Ghost, grazie alla quale quando la luce è spenta, lo specchio rimane puro, la luce viene azionata dall'interruttore touch _____ The Pollux mirror is equipped with Ghost technology, thanks to which when the light is switched off, the mirror remains pure, the light is operated by the touch switch _____ Le miroir Pollux est équipé de la technologie Ghost, grâce à laquelle lorsque la lumière est éteinte, le miroir reste pur, la lumière est commandée par l'interrupteur tactile _____ Der Pollux-Spiegel ist mit der Ghost-Technologie ausgestattet, dank derer bei ausgeschaltetem Licht der Spiegel rein bleibt, das Licht wird über den Touch-Schalter bedient _____ El espejo Pollux está equipado con la tecnología Ghost, gracias a la cual cuando se apaga la luz, el espejo permanece puro, la luz se acciona mediante el interruptor táctil

M3 System _____ Matter forms emotions



Materials Suggestions | G |

- _01 Dekorativo 3D Castagno Malto - 1C2
- _02 Dekorativo 3D Eucalipto Lab Naturale - 1E1
- _03 Dekorativo 3D Rovere Dogato Naturale - 1P3
- _04 Laccato Verde Salvia - 242
- _05 Laccato Metal Titanio - 2MC
- _06 Gres Ossido Bruno - TQT





___ Nello scorrere di un fiume si avverte il flusso dell'acqua, si percepisce attraverso il suo movimento il vento ed il riflesso dai contorni sfocati di ciò che accade intorno. Una metafora della vita che ci vede spettatori e insieme protagonisti di ciò che continuamente si trasforma, cambia prospettiva. Una lampada a Led ruota sullo specchio per trovare della luce l'inclinazione migliore. La matericità, il design e le cromie di questa composizione, vibrano di naturali energie, che ritroviamo negli elementi a terra in laccato Canapa opaco, come nella barra portaoggetti e portasalviette Look in metallo verniciato Creta metallizzato.

___ In the flow of a river you can feel the flow of water, you can perceive through its movement the wind and the blurred reflection of what is happening around you. A metaphor of life that sees us as spectators and at the same time protagonists of what is continuously transformed and changes perspective. A LED lamp rotates on the mirror to find the best angle for the light. The materiality, design and colours of this composition vibrate with natural energies, which can be found in the floor elements in matt Canapa lacquer, as well as in the Look storage bar and towel rack in Metallised Creta painted metal.

___ Dans le courant d'une rivière, vous pouvez sentir le flux de l'eau, vous pouvez percevoir à travers son mouvement le vent et le reflet flou de ce qui se passe autour de vous. Une métaphore de la vie qui nous considère comme spectateurs et en même temps protagonistes de ce qui se transforme continuellement et change de perspective. Une lampe LED tourne sur le miroir afin de trouver le meilleur angle pour la lumière. La matérialité, le design et les couleurs de cette composition vibrent d'énergies naturelles, que l'on retrouve dans les éléments du sol en laque Canapa mate, ainsi que dans la barre de rangement Look et le porte-serviettes en métal peint Creta Métallisé.

___ In der Strömung eines Flusses können Sie den Fluss des Wassers spüren, Sie können durch seine Bewegung den Wind und die verschwommene Reflexion dessen, was um Sie herum geschieht, wahrnehmen. Eine Metapher des Lebens, die uns als Zuschauer und gleichzeitig als Protagonisten dessen sieht, was sich ständig verändert und die Perspektive wechselt. Eine LED-Lampe dreht sich auf dem Spiegel, um den besten Winkel für das Licht zu finden. Die Materialität, das Design und die Farben dieser Komposition schwingen mit natürlichen Energien, die sich in den Bodenelementen aus mattem Canapa-Lack sowie in den Ablage und Handtuchhalter der Seiren Look aus Metall aus Creta Metalllack lackiert wiederfinden.

___ En la corriente de un río puedes sentir el flujo del agua, puedes percibir a través de su movimiento el viento y el reflejo borroso de lo que ocurre a tu alrededor. Una metáfora de la vida que nos ve como espectadores y a la vez protagonistas de lo que se transforma continuamente y cambia de perspectiva. Una lámpara LED gira sobre el espejo para encontrar el mejor ángulo para la luz. La materialidad, el diseño y los colores de esta composición vibran con energías naturales, que se encuentran en los elementos del suelo en laca opaca Canapa, así como en la barra de almacenamiento y el toallero Look en metal pintado Creta Metalizado.



Tagliamento _F.V.G_ Italy





_____ Top Sp. 1,2 cm, con vasca integrata Prisma L. 60 cm, in HPL Pulpis Chiaro. _____
 Top Th. 1.2 cm, with Prisma integrated washbasin L.60 cm, in HPL Pulpis Chiaro.
 _____ Plan Ép.1,2, cm avec vasque intégrée Prisma L. 60 cm, en HPL Pulpis Chiaro.
 _____ Platte St. 1,2 cm, mit integrierter Waschbecken Prisma B. 60 cm, aus HPL Pulpis
 Chiaro. _____ Encimera Esp. 1,2 cm, con lavabo integrado Prisma L. 60 cm,
 en HPL Pulpis Chiaro.

_____ La lampada Watch è dotata di illuminazione superiore ed inferiore; è orientabile fino ad un angolazione di 90° e si alimenta tramite il punto luce dello specchio Loop. _____ The Watch lamp has top and bottom lighting; it can be swivelled to an angle of 90° and is powered by the light point on the Loop mirror. _____ L'applique Watch est dotée d'un éclairage supérieur et inférieur ; elle peut pivoter sur un angle de 90° et est alimentée par le point lumineux du miroir Loop. _____ Die Watch-Lampe hat eine obere und eine untere Beleuchtung; sie kann in einem Winkel von 90° geschwenkt werden und wird durch den Lichtpunkt am Loop-Spiegel gespeist. _____ La lámpara Watch tiene iluminación superior e inferior; puede girar en un ángulo de 90° y se alimenta del punto de luz del espejo Loop.





M3 System _____ Matter forms emotions

_____ La base a terra è composta da due elementi con singolo cassetto e un elemento con vano a giorno in Dekorativo 3D Noce rigato Canaletto Naturale, la gola segue le cromie della struttura e dei frontali.

_____ The floor-standing base unit consists of two elements with a single drawer and one element with an open compartment in Dekorativo 3D Noce rigato Canaletto Naturale. Groove follow the colours of structures and fronts.

_____ L'élément bas au sol est composé de deux éléments avec un seul tiroir et d'un élément avec un compartiment ouvert en Dekorativo 3D Noce rigato Canaletto Naturale. Gorge suit les couleurs de la structure et des façades. _____ Der bodenstehende Unterschrank besteht aus zwei Elementen mit einer einzelnen Schublade und einem Element mit einem offenen Fach in Dekorativo 3D Noce rigato Canaletto Naturale. Griffmulde folgt die Farben der Struktur und der Fronten. _____ La base al suelo se compone de dos elementos con un solo cajón y un elemento con un compartimento abierto Dekorativo 3D Noce rigato Canaletto Naturale. La Gola sigue los colores de la estructura y los frentes.





___ Osservando la sezione di un albero secolare, possiamo contare nei suoi cerchi, antiche memorie, nelle superfici delle basi sospese leggiamo le venature di un Dekorativo Castagno chiaro come il naturale richiamo alla natura. Lo specchio Eclisse domina il piano in Deimos Stone Grigio Cemento ad alto spessore, come una luna piena, disegnata da raffinate luci Led lungo la sua circonferenza.

___ Observing the section of a centuries-old tree, we can count ancient memories in its circles; in the surfaces of the suspended base units we can read the veins of a Dekorativo Castagno chiaro as a natural reminder of nature. The Eclisse mirror dominates the top in thick Deimos Stone Grigio Cemento, like a full moon, designed by refined LED lights along its circumference.

___ En observant la section d'un arbre séculaire, on peut compter les souvenirs anciens dans ses cercles ; dans les surfaces des éléments bas suspendus, on peut lire les veines du Dekorativo Castagno chiaro comme un rappel naturel de la nature. Le miroir Eclisse domine le plan en épaisse Deimos Stone Grigio Cemento, comme une pleine lune, dessinée par des lumières LED raffinées sur son pourtour.

___ Wenn wir den Schnitt eines jahrhundertealten Baumes betrachten, können wir in seinen Kreisen alte Erinnerungen zählen; in den Oberflächen der aufgehängten Sockel können wir die Adern des Dekorativo Castagno chiaro deutlich als natürliche Erinnerung an die Natur lesen. Der Spiegel Eclisse dominiert die Platte aus dickem Deimos Stone Grigio Cemento, wie ein Vollmond, der von raffinierten LED-Leuchten entlang seines Umfangs gestaltet wird.

___ Observando la sección de un árbol centenario, podemos contar antiguos recuerdos en sus círculos; en las superficies de las bases suspendidas podemos leer las venas de Dekorativo Castagno chiaro como un recuerdo natural de la naturaleza. El espejo Eclisse domina la parte superior en grueso Deimos Stone Grigio Cemento, como una luna llena, diseñada por refinadas luces LED a lo largo de su circunferencia.



Nature _F.V.G_ Italy





_____ La specchiera Eclisse è impreziosita da un perimetro in plexiglas illuminato led, comandabile da un interruttore touch. D'effetto i pensili con vano a giorno illuminato. _____ The Eclisse mirror is embellished with an LED-lit Plexiglas perimeter, controlled by a touch switch. Impressive wall units with illuminated open compartment. _____ Le miroir Eclisse est agrémenté d'un périmètre en plexiglas éclairé par des LED, commandé par un interrupteur tactile. Impressionnantes les éléments hauts avec compartiment ouvert éclairé. _____ Der Eclisse-Spiegel ist mit einer LED-beleuchteten Plexiglasumrandung versehen, die über einen Touch-Schalter gesteuert wird. Beeindruckend sind die Hängeschränke mit beleuchtetem offenen Fach. _____ El espejo Eclisse está adornado con un perímetro de plexiglas iluminado por LEDs, controlado por un interruptor táctil. Impresionantes los muebles altos con compartimento abierto iluminado.

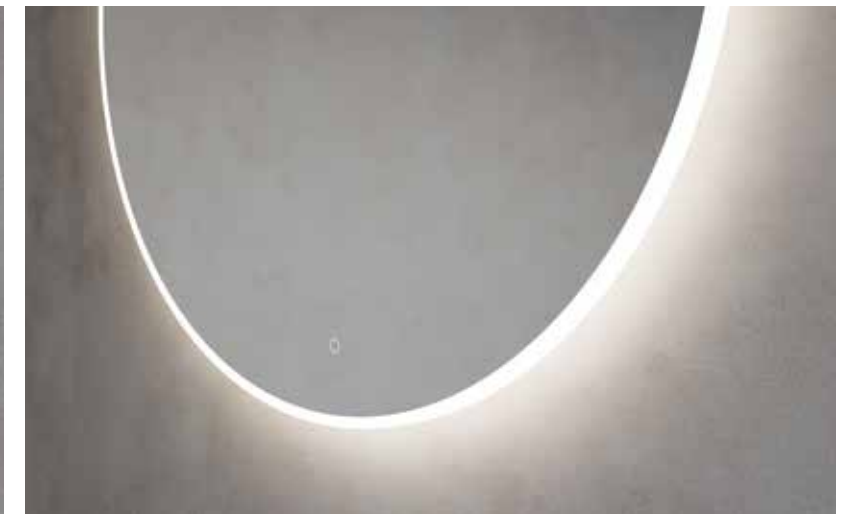

_____ Dettagli dell'attrezzatura interna modulare in metallo grigio Stone, fondo effetto pelle.
_____ Details of the internal modular equipment in Grigio Stone metal, leather-effect bottom.
_____ Détails de l'équipement modulaire interne en métal Grigio Stone, fond effet cuir. _____ Details der
modularen Innenausstattung aus Grigio Stone Metall, Boden in Ledereffekt. _____ Detalles del equipamiento
modular interno en metal Grigio Stone, fondo efecto cuero.



_____ Il lavabo Tutto Fuori Dream 04 (Ø48 cm), in Ceramica Bianco opaco, poggia sul Top Sp. 13 cm in Deimos Stone Grigio Cemento, creando un armonico contrasto materico. _____ The Dream 04 Sit-on washbasin (Ø48 cm) in matt White Ceramic rests on the 13 cm thick top in Deimos Stone Grigio Cemento, creating a harmonious contrast of materials. _____ La vasque à poser Dream 04 (Ø48 cm) en Céramique Blanche mat repose sur le plan de 13 cm d'épaisseur en Deimos Stone Grigio Cemento, créant ainsi un contraste harmonieux de matériaux. _____ Das Aufsatzbecken Dream 04 (Ø48 cm) aus mattweißer Keramik ruht auf der 13 cm dicken Platte aus Deimos Stone Grigio Cemento und bildet einen harmonischen Materialkontrast. _____ El lavabo externo Dream 04 (Ø48 cm) de Cerámica Blanca mate se apoya en la encimera de 13 cm de espesor de Deimos Stone Grigio Cemento, creando un armonioso contraste de materiales.



M3 System _____ Matter forms emotions

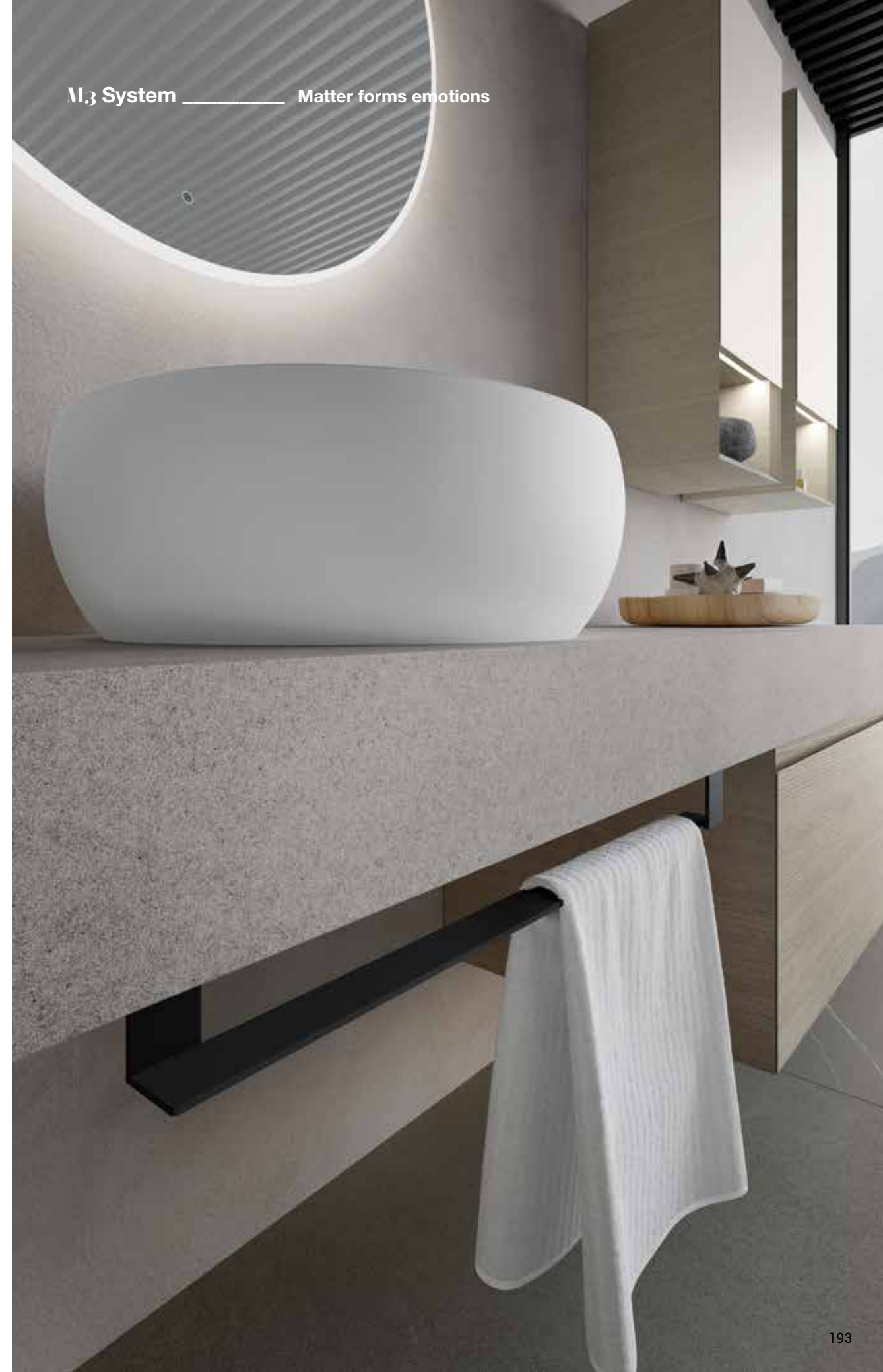

- _01 Dekorativo 3D Castagno Chiaro - 1C1
- _02 Dekorativo 3D Noce Rigato Grigio - 1N3
- _03 GRES Ossido Nero - TQ5
- _04 Laccato Blu Artico - 237
- _05 Laccato Metal Acciaio - 2MA
- _06 GRES Statuario Lucidato - TQC





___ Una composizione minimalista e al tempo stesso ricca di suggestioni materiche, quella interpretata da questa soluzione d'arredo a basi sospese in Dekorativo Eucalipto Lab Naturale che trovano nei vani a giorno laccati Castoro Ottawa, un intervallo espositivo di grande raffinatezza. M3 System è molto più di un arredo bagno, ma la capacità di creare ambienti open space per il vostro benessere intimi e confortevoli.

___ A minimalist composition that is at the same time rich in matter suggestions, the one interpreted by this decorating solution with suspended base units in Dekorativo Eucalipto Lab Naturale that find in the open compartments in Castoro Ottawa lacquer, a display interval of great refinement. M3 System is much more than a bathroom furniture, but the ability to create open space environments for your intimate and comfortable well-being.

___ Une composition minimaliste mais riche en suggestions matérielles, interprétée par cette solution d'ameublement avec des meubles bas suspendus en Dekorativo Eucalipto Lab Naturale qui trouvent dans les compartiments ouverts en laque Castoro Ottawa, un intervalle de présentation de grand raffinement. Le système M3

est bien plus qu'un système d'ameublement pour la salle de bains, il est la capacité de créer des environnements d'espace ouvert pour votre bien-être intime et confortable.

___ Eine minimalistische Komposition, die gleichzeitig reich an materiellen Anregungen ist, wird von dieser Einrichtungslösung mit wandhängenden Unterschränken in Dekorativo Eucalipto Lab Naturale interpretiert, die in den offenen Fächern in Lack Castoro Ottawa einen Ausstellungsbereich von großer Raffinesse finden. M3 System ist viel mehr als ein Badmöbelsystem, sondern die Fähigkeit, offene Raumumgebungen für Ihr Wohlbefinden intim und komfortabel zu schaffen.

___ Una composición minimalista y al mismo tiempo rica en sugerencias materiales, la interpretada por esta solución de mobiliario con muebles bajos suspendidos en Dekorativo Eucalipto Lab Naturale que encuentran en la laca Castoro Ottawa, un intervalo de visualización de gran refinamiento. El Sistema M3 es mucho más que un sistema de mobiliario de baño, pero la capacidad de crear ambientes de espacio abierto para su bienestar íntimo y cómodo.



Nature _F.V.G_ Italy







M3 System _____ Matter forms emotions



_____ Lo specchio contenitore Sky è dotato di anta a specchio bifacciale sp. 6 mm. _____ The Sky container mirror features a 6 mm thick double-sided mirror door. _____ L'armoire miroir Sky est équipé d'une porte miroir double face Ép. 6 mm. _____ Der Sky Spiegelschrank ist mit einer 6 mm dicken doppelseitigen Spiegeltür ausgestattet. _____ El espejo contenedor Sky viene con una puerta de espejo de doble cara Esp. 6 mm.



_____ Il Top Sp. 1 cm con vasca integrata Scivolo L. 70 cm, si presenta in uno splendido Gres Calacatta Oro Venato, che grazie alle sue venature addolcisce le linee della composizione. _____ The Top Th. 1 cm with Scivolo integrated washbasin W.70 cm is presented in a splendid Gres Calacatta Oro Venato, whose veining softens the lines of the composition. _____ Le plan de travail Ép.1 cm avec vasque intégrée Scivolo L. 70 cm est présenté dans un splendide Grès Calacatta Oro Venato, dont le veinage adoucit les lignes de la composition. _____ Die Platte St. 1 cm mit integrierter Waschbecken Scivolo B. 70 cm präsentiert sich in einem prächtigen Gres Calacatta Oro Venato, deren Maserung die Linien der Komposition abschwächt. _____ La encimera Esp. 1 cm lavabo integrado Scivolo L. 70 cm se presenta en un espléndido Gres Calacatta Oro Venato, cuyo vetado suaviza las líneas de la composición.





_____ Variante: Top Sp. 1,2 cm con vasca integrata Syntesi L. 58 cm Tekorlux Bianco opaco. _____ Variant: Top Th. 1.2 cm with integrated washbasin Syntesi W.58 cm Tekorlux Bianco Matt. _____ Variant: Plan Ép. 1,2 cm avec vasque intégrée Syntesi L. 58 cm Tekorlux Bianco Matt. _____ Variante: Platte St. 1,2 cm mit integrierter Waschbecken Syntesi B.58 cm Tekorlux Bianco matt. _____ Variante: Encimera Esp. 1,2 cm lavabo integrado Syntesi L.58 cm Tekorlux Bianco opaco.



___ L'originalità di questo progetto d'arredo si manifesta nella disposizione degli elementi creando spazi dedicati al bagno servito dalla vasca. Le basi sospese in Dekorativo Castagno Scuro, ospitano il doppio lavabo lui & lei in appoggio al Top della stessa finitura dei frontali. Le linee stondate in Ceramica bianca dei lavabi guardano sinergiche a quelle rigorose dello specchio Virgo, illuminato a Led.

___ The originality of this decorating project is evident in the arrangement of the elements, creating spaces dedicated to the bathroom, served by the washbasin. The suspended base units in Dekorativo Castagno Scuro house the double his-and-hers washbasins on the top in the same finish as the fronts. The rounded lines of the washbasins in white Ceramic are in synergy with the rigorous lines of the Virgo mirror, illuminated by LEDs

___ L'originalité de ce projet d'ameublement se manifeste dans la disposition des éléments, créant des espaces dédiés à la salle de bains, desservis par la vasque. Les meubles bas suspendus en Dekorativo Castagno Scuro accueillent les doubles vasques pour hommes et femmes à poser sur le Plan dans la même finition que les façades. Les lignes arrondies des vasques en céramique blanche sont en synergie avec les lignes rigoureuses du miroir Virgo, éclairé par des LED.

___ Die Originalität dieses Einrichtungsprojekts zeigt sich in der Anordnung der Elemente, die dem Bad gewidmete Räume schaffen, die von dem Waschbecken. Die wandhängenden Unterschränke in Dekorativo Castagno Scuro beherbergen die Doppelwaschbecken für ihn/sie auf der Oberseite in der gleichen Ausführung wie die Fronten. Die abgerundeten Linien der weißen Keramik Waschbecken stehen in Synergie mit den strengen Linien des Virgo-Spiegels, der von LEDs beleuchtet.

___ La originalidad de este proyecto de mobiliario se manifiesta en la disposición de los elementos, creando espacios dedicados al baño, servidos por la cuba. Los muebles bajos suspendidos en Dekorativo Castagno Scuro, albergan las cubas dobles para él/ para ella en la parte superior en el mismo acabado que los frentes. Las líneas redondeadas de la cerámica blanca de las cubas están en sinergia con las líneas rigurosas del espejo Virgo, iluminado por LEDs.



Caorle _ Italy



_____ La specchiera Virgo presenta un caratteristico telaio in alluminio verniciato Nero opaco, la lampada integrata è comandata da un interruttore touch. _____ The Virgo mirror features a distinctive matt Nero painted aluminium frame, the integrated lamp is controlled by a touch switch. _____ Le miroir Virgo se distingue par son cadre en aluminium peint en Nero mat. La lampe intégrée est commandée par un interrupteur tactile. _____ Der Virgo-Spiegel hat einen markanten Nero matt lackierten Aluminiumrahmen, die integrierte Lampe wird über einen Touch-Schalter gesteuert. _____ El espejo Virgo tiene un marco de aluminio pintado en Nero opaco, la lámpara integrada se controla con un interruptor táctil.



_____ Composizione Lui & Lei formata da un elemento con cassetto in Dekorativo 3D Noce rigato Canaletto naturale e da un elemento con vano a giorno laccato Grigio Talpa. _____ Him & Her composition consisting of an element with drawer in Dekorativo 3D Noce rigato Canaletto naturale and an element with open compartment lacquered Grigio Talpa. _____ Lui & Elle composition composée d'un élément avec tiroir en Dekorativo 3D Noce rigato Canaletto naturelle et d'un élément avec compartiment ouvert laqué Grigio Talpa. _____ Er/Sie Komposition bestehend aus einem Element mit Schublade in Dekorativo 3D Noce rigato Canaletto naturale und einem Element mit offenem Fach lackiert Grigio Talpa. _____ Composición para Él y Ella formada por un elemento con cajón en Dekorativo 3D Noce rigato Canaletto naturale y un elemento con compartimento abierto lacado Grigio Talpa.

_____ La specchiera Starlight è delimitata da un perimetro in plexiglass illuminato a Led con interruttore touch. _____ The Starlight mirror is bordered by a Plexiglas perimeter with LED lighting and touch switch. _____ Le miroir Starlight est bordé d'un périmètre en plexiglas avec éclairage LED et interrupteur tactile. _____ Der Starlight-Spiegel wird von einem Plexiglasrand mit LED-Beleuchtung und Touch-Schalter eingefasst. _____ El espejo Starlight está bordeado por un perímetro de plexiglas con iluminación LED e interruptor táctil.



C 318 Var



M3 System _____ Matter forms emotions

_____ Il lavabo Tutto Fuori Smart B02 L. 55 P. 38 in Ceramica Bianco opaco poggia su un Top Sp. 1 cm in Dekorativo 3D Noce Rigato Canaletto naturale. _____ The Smart B02 Sit-on Washbasin W. 55 P. 38 in matt White Ceramic rests on a Top Th. 1 cm in Dekorativo 3D Noce Rigato Canaletto naturale. _____ La vasque à poser Smart B02 L. 55 P. 38 en céramique blanche mate est posée sur un plan Ép. 1 cm en in Dekorativo 3D Noce Rigato Canaletto naturale. _____ Der Aufsatzbecken Smart B02 B. 55 T. 38 in Keramik Weiß matt ruht auf einer Platte St. 1 cm aus Dekorativo 3D Noce Rigato Canaletto naturale. _____ El lavabo externo Smart B02 L. 55 P. 38 de cerámica blanca mate se apoya en una encimera Esp. 1 cm en in Dekorativo 3D Noce Rigato Canaletto naturale.

Materials Suggestions | I |

- _01 Dekorativo 3D Noce Rigato
Canaletto Naturale - 1N2
- _02 Dekorativo 3D Noce Rigato Chiaro - 1N1
- _03 Gres Pietra Piasentina Grigia - TQP
- _04 Laccato Rosso Jaipur - 2FH
- _05 Gres Cava Noir Desir - TQH
- _06 Deimos Stone Tabacco - TTE



M3 System Colori e finiture

Colours and finishes
Couleurs et finitions
Farben und Oberflächen
Colores y acabados

10 Essenze

32 Dekorativo 3D

12 HPL Unicolor

58 Laccati

58 Lacquered Colours
58 Couleurs Laquées 58
Lackierte Farben 58
Colores Lacados

M3 System Colours and finishes

Vengono qui presentati i materiali e le cromie che compongono la proposta Baxar. Un'ampia scelta pensata per assecondare i rituali quotidiani, in armonia con il proprio essere.

___ The materials and colours that compose the Baxar range are presented here. A wide choice designed to support daily rituals, in harmony with one's own being.

___ Les matériaux et les couleurs qui composent la gamme Baxar sont présentés ici. Un large choix conçu pour soutenir les rituels quotidiens, en harmonie avec son propre être.

___ Die Materialien und Farben, aus denen die Baxar-Palette besteht, werden hier vorgestellt. Eine große Auswahl zur Unterstützung der täglichen Rituale, in Harmonie mit dem eigenen Wesen.

___ Aquí se presentan los materiales y colores que componen la gama Baxar. Una amplia selección diseñada para apoyar los rituales diarios, en armonía con el propio ser.

M3 System

Essenze

Le essenze legnose rappresentano la matericità per eccellenza, conferiscono calore, forza e atmosfera all'area bagno, la loro applicazione è principalmente dedicata ai frontali di ante e cassetti, ma sono estremamente arricchenti come schienali per elementi a giorno e accuratamente mixati con i Gres ed i laccati concorrono a creare progetti d'arredo estremamente raffinati.

Wooden essences represent matter by excellence, giving warmth, strength and atmosphere to the bathroom area, mainly used for the door and drawer fronts, they are extremely enriching as back panels of open elements, and carefully mixed with Gres and lacquered finishes they contribute to create extremely refined furnishing projects.

Les essences de bois représentent la matérialité par excellence, donnant chaleur, force et atmosphère à l'espace salle de bains, principalement utilisés pour les façades de portes et de tiroirs, ils sont extrêmement enrichissants en tant que dos d'éléments ouverts, et soigneusement mélangés avec les Grès et des laques, ils contribuent à créer des projets d'ameublement extrêmement raffinés.

Hölzerne Essenzen stehen für die Materialität schlechthin und verleihen dem Badezimmer Wärme, Kraft und Atmosphäre, sie werden hauptsächlich für Tür- und Schubladenfronten verwendet, sind aber auch als Rückwand für offene Elemente eine große Bereicherung. Sorgfältig gemischt mit Gres und Lacken tragen sie dazu bei, äußerst raffinierte Einrichtungsprojekte zu schaffen.

Las esencias de madera representan la materialidad por excelencia, dando calidez, fuerza y ambiente a la zona de baño, principalmente para los frentes de puertas y cajones, son extremadamente enriquecedores como respaldos de elementos abiertos, y mezclados cuidadosamente con Gres y lacas contribuyen a crear proyectos de decoración extremadamente refinados.

ROVERE BIANCO_06A

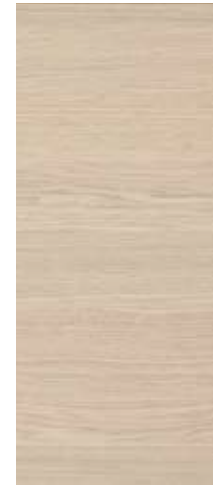

ROVERE CENERE_06D



ROVERE CARBONE_06G



ROVERE NATURALE_06B



ROVERE Avena_06E



ROVERE MOKA_06H



ROVERE SABBIA_06C

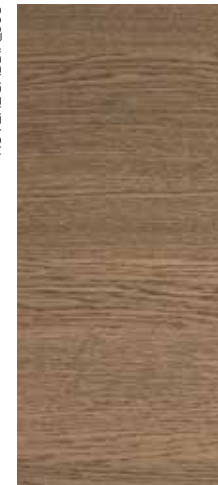

ROVERE FUMO_06F



ROVERE NERO_06J



EUCALIPTO_01A

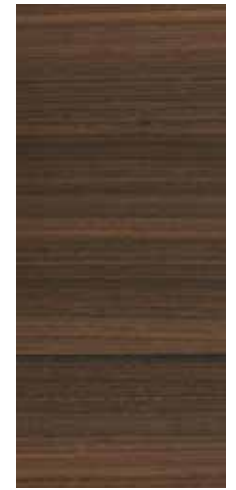

M3 System

Dekorativo 3D

Melaminico usato per realizzare strutture, frontali, elementi giorno, top e anche per il rivestimento delle gole. Top sp.6 cm realizzato in Laminato Dekorativo 3D

Verwendet wird es für Strukturen, Fronten, offene Elemente, Waschtischplatten sowie auch für die Verkleidung der Griffmulden. Platte St. 6 cm aus Melamin Dekorativo 3D

Melamine finish used for structures, front panels, open elements, tops and also for groove coating. Top 6 cm thick in Laminate Dekorativo 3D

Melaminico usado para realizar estructuras, frontales, elementos abiertos, encimeras y también para el revestimiento de las golas. Encimera Esp. 6 cm realizada en Laminado Dekorativo 3D

Méla miné utilisé pour réaliser les structures, les façades, les éléments ouverts, les plans vasques et aussi le revêtement des gorges. Plan travail ép. 6 cm en mélamine Dekorativo 3D

RIGATINO NATURALE_1RN

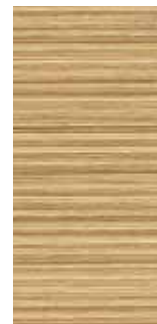

RIGATINO TABACCO_1RP



RIGATINO BETON_1RQ



CASTAGNO SCURO_1C3



CASTAGNO CHIARO_1C1



CASTAGNO MALTO_1C2



ROVERE DOGATO NATURALE_1P3



NOCE RIGATO GRIGIO_1N3

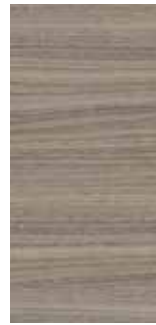

EUCALIPTO LAB AFFUMMICATO_1E2



NOCE RIGATO CHIARO_1N1



NOCE RIGATO CANALETTO NAT_1N2



PAULOWNIA - SEPPIA_1F2



CEMENTO GHIACCIO_1A5



ROVERE DOGATO BIANCO_1P0



COLORTECH BIANCO_10B



CEMENTO CENERE_1A1



ROVERE SHERWOOD CHIARO_1S1



ROVERE DOGATO GRIGIO_1P1



NODATO SPACCATO TABACCO_1NB



CEMENTO TORTORA_1A2



ROVERE SHERWOOD CASTANO_1S3



PELLE PECARI TORTORA_1PE

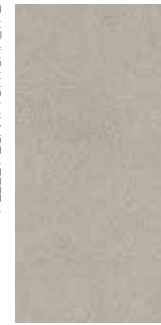

CEMENTO CRETA_1A3



ROVERE SHERWOOD SCURO_1S2



PIETRA PIASENTINA GRIGIO CHIARO_1AA



CEMENTO OLTREMARE_1A4



NOCE TAVOLA ANTICO CHIARO_1ND



NOCE TAVOLA ANTICO SCURO_1NE



PIETRA PIASENTINA GRIGIO SCURO_1AB



M3 System

Laccati

LACCATI OPACHI, LUCIDI, SOFT-TOUCH

Laccati usati per realizzare strutture, frontali, elementi giorno, top e anche per il rivestimento delle gole.
53 Colori Laccati in finitura Lucida - Opaca - Soft-touch.
5 Colori Metallizzati Laccati in finitura Lucida - Opaca - Soft-touch.
53 colori Soft-Touch: Laccato molto opaco con finitura superficiale morbida al tatto, anti-impronta, a bassa riflessione della luce, resistente ai graffi e all'abrasione.
9 colori Soft-touch Abbinabili agli stessi colori dei top con vasca integrata realizzati in Fenix.
5 colori laccati opachi per elementi in metallo (Cube - Cleo - Kros - Look - ecc.)
4 colori Laccati Metal: Laccato opaco con componenti metallici (senza metalli pesanti), applicato artigianalmente con diversi passaggi.

MATT, GLOSSY, SOFT-TOUCH, LAQUERED FINISHES

Lacquered finishes for structures, front panels, open elements, tops and also for groove coating.
53 colours: Gloss - Matt - Soft-touch finish
5 Colours Metallised Lacquers in Gloss - Matt- Soft-touch finish.
53 colours Soft-Touch: Ultra-matt lacquer with soft-touch, fingerprint-proof, low light reflection finish and scratch and abrasion resistance.
9 colours Soft-Touch available in the same colours as the Fenix tops with integrated basin.
5 matt lacquered colours for metal parts (Cube - Cleo - Kros - Look)
4 Metal lacquered colours: matt lacquered with metallic components (no heavy metals), applied using traditional techniques in various steps.

FINITIONS LAQUÉES MATES, BRILLANTES, SOFT-TOUCH

Finitions laquées utilisées pour réaliser les structures, les façades, les éléments ouverts, les plans de toilettes, mais aussi le revêtement des gorges.
53 couleurs: Finitions laquées brillantes - mates Soft-touch.
5 couleurs Métallisées laquées en finition brillante - mate - Soft-touch.
53 couleurs Soft-Touch: Il s'agit d'une finition laquée très mate avec une finition superficielle douce au toucher, anti-trace, à basse réflexion de la lumière, résistant aux rayures et à l'abrasion.
9 couleurs Soft-Touch assorties aux mêmes couleurs que les plans de toilette avec vasque intégrée réalisée en Fenix.
5 couleurs laquées mat pour éléments en métal (Cube - Cleo - Kros - Look)
4 couleurs laquées Metal: Il s'agit d'une finition laquée mate aux composants métalliques (sans métaux lourds), appliquée artisanalement en plusieurs couches.

MATT LACKIERT, GLÄNZEND, SOFT-TOUCH

Lacke zur Herstellung von Strukturen, Frontseiten, offenen Elementen, Waschtischplatten, Abdichtungsflächen und auch zum Verkleiden der Gruffmulden.
53 Farben: Lackiert im Finish Glänzend - Matt - Soft-Touch.
5 Metallik-lackiert Farben in Finish Glänzend - Matt - Soft-Touch.
53 Farben Soft-Touch: Sehr deckender Lack mit Soft-Touch-Oberfläche, Antifingerabdruckt, geringer Lichtreflexion, Kratz- und Abriebfestigkeit.
9 Soft-Touch Farben kombinierbar mit den gleichen Farben wie die Aufsätze mit integrierten Wannen aus Fenix.
5 Farbe matt lackiert für Metallelemente (Cube - Cleo - Kros - Look)
4 lackierte Farben Metal: Matt lackiert mit Metallteilen (ohne Schwermetalle), in mehreren Arbeitsschritten von Hand aufgetragen.

LACADOS MATES, BRILLANTES, SOFT-TOUCH

Lacados usados para realizar estructuras, frontales, elementos abiertos, encimeras y también para el revestimiento de las golas.
53 Colores: Lacados en acabado Brillo - Mate - Soft-touch.
5 Colores Lacados Metalizados en acabado Brillante - Mate - Soft-touch.
53 colores Soft-Touch: Lacado muy mate con acabado superficial suave al tacto, anti-huellas, con baja reflexión de la luz, resistente a los arañazos y a la abrasión.
9 colores Soft-touch Combinables con los mismos colores de las encimeras en Fenix con cuba integrada.
5 colores lacados mate para elementos metálicos (Cube - Cleo - Kros - Look - etc.)
4 colores Lacados Metal: Lacado mate con componentes metálicos (sin metales pesados), aplicado artesanalmente con diversos pasos.

Metal

ACCIAIO_2MA

PIOMBO_2MB

TITANIO_2MC

BRONZO_2MD



M3 System

Laccati opachi, Lucidi, Soft-touch.

Matt, Glossy, Soft-Touch Lacquered Finishes / Finitions Laquées Mates, Brillantes, Soft-Touch / Matt Lackiert, Glänzend, Soft-Touch / Lacados Mates, Brillantes, Soft-Touch



N° 9 Colori Laccati Soft-touch abbinati ai Top in Fenix® _9 lacquered Soft-Touch colours matching the Fenix® tops _9 Couleurs Laquées Soft-Touch assorties aux Plan-travail en Fenix® _9 Soft-Touch lackierten Farben, mit den Platten aus Fenix® kombiniert __N° 9 Colores lacados Soft-touch combinados a las encimeras en Fenix®



N° 5 Colori per elementi in metallo __5 colours for metal elements __5 Couleurs pour éléments en métal __5 Farben für Elemente aus Metall __N° 5 colores para elementos de metal

M3 System



___ Il Cannelé Asimmetrico Tipo A conferisce un piacevole ritmo visivo e materico al frontale dell'arredo. Ha un motivo lineare irregolare che si ripete personalizzandolo in modo elegante e dinamico. ___ Asymmetrical Cannelé Type A lends a pleasing visual and material rhythm to the furniture front. It has an irregular linear pattern that is repeated in an elegant and dynamic way. ___ Le Cannelé Asymétrique Type A donne un rythme visuel et matériel agréable aux façades. Il a un motif linéaire irrégulier qui se répète en le personnalisant de manière élégante et dynamique. ___ Das asymmetrische Cannelé Typ A verleiht der Möbelfront einen angenehmen visuellen und materiellen Rhythmus. Es hat ein unregelmäßiges lineares Muster, das sich auf elegante und dynamische Weise wiederholt. ___ El Cannelé Asimétrico Tipo A aporta un agradable ritmo visual y material al frente del mueble. Presenta un patrón lineal irregular que se repite de forma elegante y dinámica.



___ Disponibile nei 58 colori Laccati Opachi (escluso i Metal).
 ___ Available in 58 matt lacquer colours (excluding Metal).
 ___ Disponible en 58 couleurs laquées mates (hors Métal).
 ___ Erhältlich in 58 Mattlackfarben (außer Metall).
 ___ Disponible en 58 colores de laca mate (excepto Metal).

Cannelé Asimmetrico Tipo A __Cannelé Asymmetrical Type A

Frontali e fianchi__ Fronts and sides



___ TIPO A_VERTICALE ___ TYPE A_VERTICAL



___ TIPO A_ORIZZONTALE ___ TYPE A_HORIZONTAL



M3 System



___ Il Cannelé Simmetrico Tipo B caratterizza il frontale dell'arredo con un andamento classico, regolare esaltandone la verticalità.
 ___ Symmetrical Cannelé Type B characterises the front of the furniture with a classic, regular course, enhancing its verticality.
 ___ La Cannelé Symétrique Type B caractérise la façade du meuble avec une tendance classique, rehaussant régulièrement sa verticalité.
 ___ Das symmetrische Cannelé Typ B charakterisiert die Fronten der Möbel mit einem klassischen, regelmäßigen Verlauf, der die Vertikalität des Möbels betont.
 ___ Cannelé Simétrico Tipo B caracteriza el frente del mueble con un curso clásico y regular, realzando su verticalidad.



___ Disponibile nei 58 colori Laccati Opachi (escluso i Metal).
 ___ Available in 58 matt lacquer colours (excluding Metal).
 ___ Disponible en 58 couleurs laquées mates (hors Métal).
 ___ Erhältlich in 58 Mattlackfarben (außer Metall).
 ___ Disponible en 58 colores de laca mate (excepto Metal).

Cannelé Simmetrico Tipo B

Frontali e fianchi__ Fronts and sides



___ TIPO B_VERTICALE ___ TYPE B_VERTICAL



___ TIPO B_ORIZZONTALE ___ TYPE B_HORIZONTAL



M3 System

HPL Unicolor

Usato per realizzare strutture, frontali, elementi giorno, top e top con vasca integrata, fianchi di tamponamento e anche per il rivestimento delle gole.

Used for structures, front panels, open elements, tops and top with integrated washbasin, and also for groove coating.

Utilisé pour réaliser les structures, les façades, les éléments ouverts, les plans sans et avec vasque intégrée, les fileurs et aussi le revêtement des gorges.

Verwendet wird es für Strukturen, Fronten, offene Elemente, Waschtischplatten mit und ohne integriertem Waschbecken sowie auch für die Verkleidung der Griffmulden.

Usado para realizar estructuras, frontales, elementos abiertos, encimeras y encimeras con cuba integrada, y también para el revestimiento de las golas.



M3 System



M3 System

__ Grain direction change, fronts with continous grain, Grain direction change and fronts with continous grain

Diverse soluzioni Baxar interpretano in modo nuovo le venature del legno con singolarità e carattere. Alternative regolari invece risaltano la bellezza e il senso di continuità delle venature senza nette interruzioni.

___ Different Baxar solutions interpret the wood grain in a new way with uniqueness and character. Regular alternatives, on the other hand, emphasise the beauty and sense of continuity of the grain without clear interruptions.

___ Différentes solutions Baxar qui interprètent le veinage (grain du bois) d'une manière nouvelle avec singularité et caractère. Les alternatives régulières, d'autre part, soulignent la beauté et le sentiment de continuité des veines sans interruption nette.

___ Verschiedene Lösungen von Baxar interpretieren die Maserung des Holzes auf neue Art und Weise mit Einzigartigkeit und Charakter. Regelmäßige Alternativen hingegen betonen die Schönheit und das Gefühl der Kontinuität der Maserung ohne deutliche Unterbrechungen.

___ Las diferentes soluciones Baxar interpretan la veta de la madera de una forma nueva, con singularidad y carácter. Las alternativas regulares, por su parte, enfatizan la belleza y la sensación de continuidad de la veta sin interrupciones claras.

M3 System

L'unicità di un frontale non banale che conferisce al mobile tratti sicuri e personali. Cambio senso vena orizzontale o verticale per disegnare in modo deciso forme e superfici.

The uniqueness of a non-trivial front that gives the furniture confident and personal traits. Change horizontal or vertical grain direction to decisively design shapes and surfaces.

Le caractère unique d'une façade non triviale qui donne aux meubles des traits sûrs et personnels. Le sens du veinage horizontal ou vertical change pour dessiner de manière décisive les formes et les surfaces.

Die Einzigartigkeit einer nicht-trivialen Front, die den Möbeln selbstbewusste und persönliche Züge verleiht. Horizontale oder vertikale Maserungen wechseln, um Formen und Flächen entscheidend zu gestalten.

La singularidad de un frente no trivial que confiere al mueble seguridad y rasgos personales. Cambie la dirección horizontal o vertical de las vetas para diseñar con decisión formas y superficies.



Cambio senso vena __ Grain direction change__

Orizzontale o verticale __ Horizontal or vertical

DEKORATIVO 3D* ESSENZE



___ **DI SERIE**_CON VENATURA IN ORIZZONTALE
___ **STANDARD**_WITH HORIZONTAL GRAIN

___ **SU RICHIESTA**_CON VENATURA IN VERTICALE
___ **ON REQUEST**_WITH VERTICAL GRAIN

___ *CAMBIO SENSO VENA NON DISPONIBILE PER LE SEGUENTI FINITURE ___ *GRAIN DIRECTION CHANGE NOT AVAILABLE FOR THE FOLLOWING FINISHES ___ COLORTECH BIANCO (10B), CEMENTO GHIACCIO (1A5), CEMENTO CENERE (1A1), CEMENTO TORTORA (1A2), CEMENTO CRETA (1A3), CEMENTO OLTREMARE (1A4), PELLE PECARI (1PE)

N.B. : COLONNE H.220 / 250 CON ANTA INTERA, FIANCHI E FRONTALE IN DEKORATIVO 3D SEMPRE CON VENATURA VERTICALE ___ N.B. : H.220 / 250 COLUMNS WITH FULL DOOR, SIDES AND FRONT IN DEKORATIVE 3D ALWAYS WITH VERTICAL GRAIN

HPL UNICOLOR*



___ **DI SERIE**_CON VENATURA IN VERTICALE
___ **STANDARD**_WITH VERTICAL GRAIN

___ **SU RICHIESTA**_CON VENATURA IN ORIZZONTALE
___ **ON REQUEST**_WITH HORIZONTAL GRAIN

___ *CAMBIO SENSO VENA NON DISPONIBILE PER LE SEGUENTI FINITURE ___ *GRAIN DIRECTION CHANGE NOT AVAILABLE FOR THE FOLLOWING FINISHES ___ CEPP STONE (TKP), ROX BLACK (TKQ), BRERA BROWN (TKN)

N.B. : COLONNE H.160 / 198 / 220 / 250 CON ANTA INTERA, FIANCHI E FRONTALE SEMPRE CON VENATURA IN VERTICALE ___ N.B. : COLUMNS H.160 / 198 / 220 / 250 WITH FULL DOOR, SIDES AND FRONT ALWAYS WITH VERTICAL GRAIN

M3 System

Senso di continuità o senso di eccezionalità? La scelta tra venatura continua, per non interrompere segni e tratti sul frontale. La scelta opposta per rivelare un frontale creativo e dinamico dove i tratti irregolari diventano i protagonisti.

Sense of continuity or sense of exceptionality? The choice between continuous grain, so as not to interrupt marks and traits on the front. The opposite choice to reveal a creative and dynamic front where irregular features become the protagonists.

Sentiment de continuité ou sens d'exceptionnalité? Le choix entre la continuité du veinage, afin de ne

pas interrompre les marques et les traits sur la façade. Le choix inverse pour révéler une façade créative et dynamique où les traits irréguliers deviennent les protagonistes.

Sinn für Kontinuität oder Sinn für Außergewöhnlichkeit? Die Wahl zwischen kontinuierlicher Maserung, um die Zeichen und Striche auf der Vorderseite nicht zu unterbrechen. Die entgegengesetzte Wahl, um eine kreative und dynamische Front zu zeigen, wo unregelmäßige Striche die Protagonisten werden.

¿Sentido de continuidad o sentido de excepcionalidad? La elección entre un vetado continuo, para no interrumpir las marcas y los rasgos del frente. La elección opuesta para revelar un frente creativo y dinámico donde los rasgos irregulares se convierten en protagonistas.



Frontali in Bilia __ Bilia fronts

Venatura continua fra frontali (con maggiorazione) __ Continuous grain between fronts (with surcharge)

DEKORATIVO 3D* ESSENZE



___ DI SERIE _CON VENATURA NON CONTINUA
___ STANDARD _WITH NON-CONTINUOUS GRAIN



___ SU RICHIESTA _CON VENATURA CONTINUA IN BILIA
___ ON REQUEST _WITH CONTINUOUS GRAIN

__ *VENATURA IN BILIA NON DISPONIBILE PER LE SEGUENTI FINITURE __ *CONTINUOUS GRAIN NOT AVAILABLE FOR THE FOLLOWING FINISHES __ COLORTECH BIANCO (10B), CEMENTO GHIACCIO (1A5), CEMENTO CENERE (1A1), CEMENTO TORTORA (1A2), CEMENTO CRETA (1A3), CEMENTO OLTREMARE (1A4), PELLE PECARI (1PE)

N.B. : COLONNE H.220 / 250 CON ANTA INTERA, FIANCHI E FRONTALE IN DEKORATIVO 3D SEMPRE CON VENATURA VERTICALE __ N.B. : H.220 / 250 COLUMNS WITH FULL DOOR, SIDES AND FRONT IN DEKORATIVO 3D ALWAYS WITH VERTICAL GRAIN

HPL UNICOLOR*



___ DI SERIE _CON VENATURA NON CONTINUA
___ STANDARD _WITH NON-CONTINUOUS GRAIN



___ SU RICHIESTA _CON VENATURA CONTINUA IN BILIA
___ ON REQUEST _WITH CONTINUOUS GRAIN

N.B. : COLONNE H.160 / 198 / 220 / 250 CON ANTA INTERA, FIANCHI E FRONTALE SEMPRE CON VENATURA IN VERTICALE __ N.B. : COLUMNS H.160 / 198 / 220 / 250 WITH FULL DOOR, SIDES AND FRONT ALWAYS WITH VERTICAL GRAIN

M3 System

Giocare con il doppio senso è la forza della metafora. In questo caso, il senso vena orizzontale o verticale si combina con il senso di continuità e asimmetria, generando design di volta in volta unici e originali.

Playing with double sense is the power of metaphor. In this case, the horizontal or vertical vein sense is combined with the sense of continuity and asymmetry, generating unique and original designs.

Jouer avec le double sens est la force de la métaphore. Dans ce cas, le veinage horizontal ou vertical est combiné avec le sens de la continuité et de l'asymétrie, générant de temps en temps des conceptions uniques et originales.

Das Spiel mit der doppelten Bedeutung ist die Kraft der Metapher. In diesem Fall wird der Sinn für horizontale oder vertikale Adern mit dem Sinn für Kontinuität und Asymmetrie kombiniert, wodurch einzigartige und originelle Designs entstehen.

Jugar con el doble sentido es el poder de la metáfora. En este caso, el sentido de veta horizontal o vertical se combina con el sentido de continuidad y asimetría, generando diseños únicos y originales.



Cambio senso vena e frontali in Bilia __ Grain direction change and fronts with continous grain

Venatura orizzontale o verticale continua tra i frontali (con maggiorazione)
 __ Continuous horizontal and vertical grain between frontals (with surcharge)

DEKORATIVO 3D* ESSENZE



__ DI SERIE _CON VENATURA ORIZZONTALE
 NON CONTINUA __ STANDARD _WITH HORIZONTAL
 GRAIN NOT CONTINUOUS



__ SU RICHIESTA _CON VENATURA VERTICALE CONTINUA
 IN BILIA __ ON REQUEST _WITH CONTINUOUS VERTICAL
 GRAIN IN BILIA

__ CAMBIO SENSO VENA IN BILIA NON DISPONIBILE PER LE SEGUENTI FINITURE __ *CHANGE OF CONTINUOUS GRAIN DIRECTION IN BILIA, NOT AVAILABLE FOR THE FOLLOWING FINISHES
 __ COLORTECH BIANCO (10B), CEMENTO GHIACCIO (1A5), CEMENTO CENERE (1A1), CEMENTO TORTORA (1A2), CEMENTO CRETA (1A3), CEMENTO OLTREMARE (1A4), PELLE PECARI (1PE)

N.B. : COLONNE H.220 / 250 CON ANTA INTERA, FIANCHI E FRONTALE IN DEKORATIVO 3D SEMPRE CON VENATURA VERTICALE __ COLUMNS H.220 / 250 WITH FULL DOOR, SIDES AND FRONT IN DEKORATIVO 3D ALWAYS WITH VERTICAL GRAIN

HPL UNICOLOR*



__ DI SERIE _CON VENATURA VERTICALE NON CONTINUA
 __ STANDARD WITH NON-CONTINUOUS VERTICAL GRAIN



__ SU RICHIESTA _CON VENATURA ORIZZONTALE CONTINUA IN BILIA __ ON REQUEST _WITH CONTINUOUS HORIZONTAL GRAIN IN BILIA

N.B. : COLONNE H.160 / 198 / 220 / 250 CON ANTA INTERA, FIANCHI E FRONTALE SEMPRE CON VENATURA IN VERTICALE __ N.B. : COLUMNS H.160 / 198 / 220 / 250 WITH FULL DOOR, SIDES AND FRONT ALWAYS WITH VERTICAL GRAIN

M3 System

Modularità

Basi / Base units
P 36,5 / 45,5 / P 50

Pensili / Wall Units
Colonne / Columns
P 21 / 27 / 36,5 / P 50



___ La modularità della collezione Baxar, favorisce la componibilità dei suoi modelli anche mediante l'uso di fianchi esterni a 45°. ___ The modularity of the Baxar collection allows its models to be assembled with the use of external 45° side panels. ___ La modularité de la collection Baxar permet d'assembler ses modèles en utilisant des joues extérieures à 45°. ___ Die Modularität der Baxar-Kollektion ermöglicht es, die Modelle mit Hilfe von 45°-Seitenteilen zusammenzusetzen. ___ La modularidad de la colección Baxar permite ensamblar sus modelos con el uso de costados de 45°.

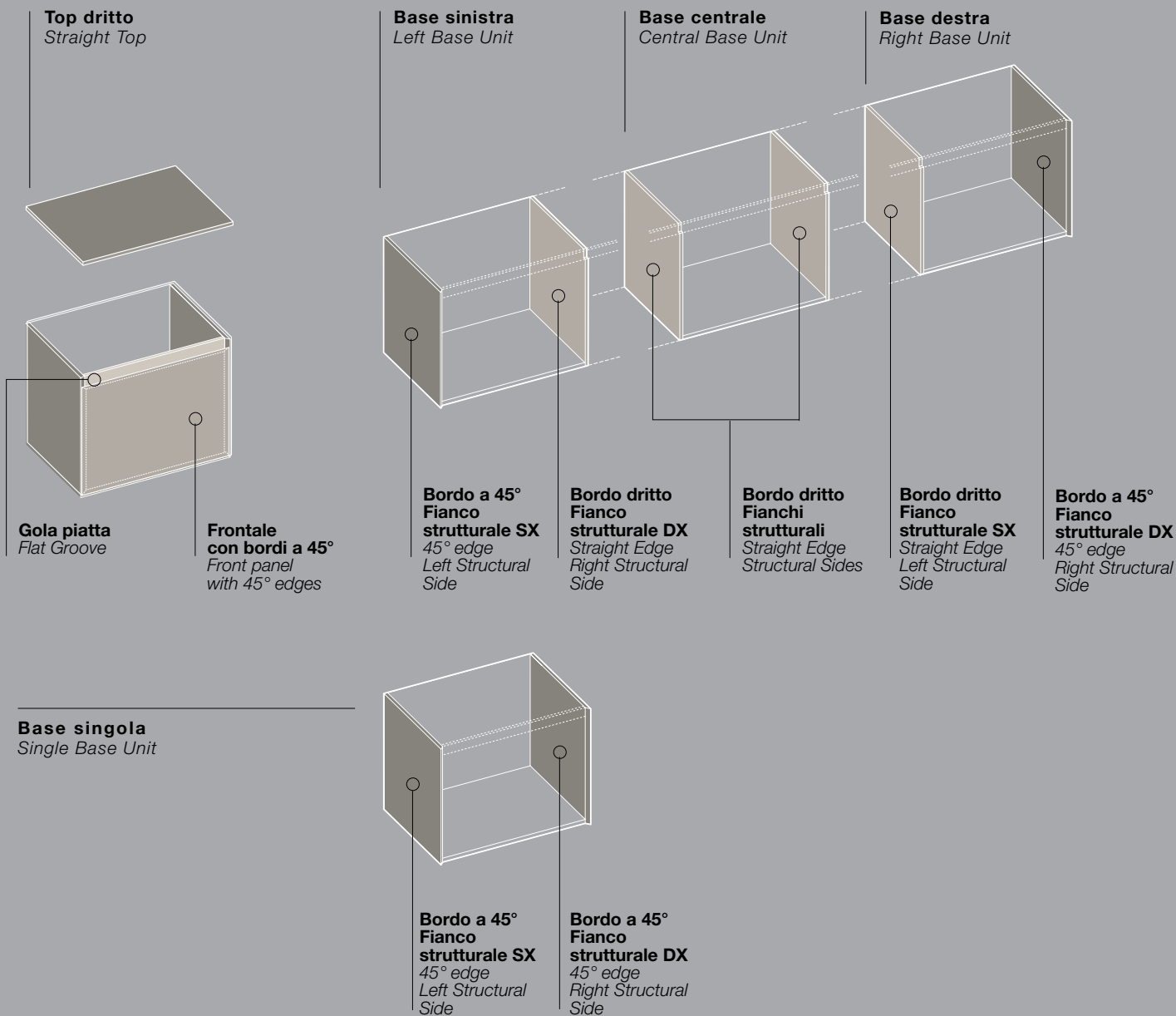

Basi Lavabo / Washbasin base units con Cassetto_Cassetti / with Drawer_Drawers **P. 36,5 - 45,5 - 50**

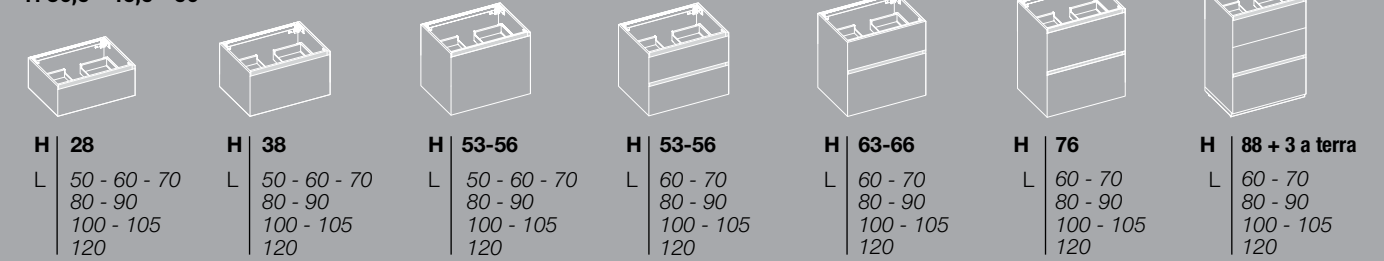

Basi / Base Units P. 36,5 - 45,5 - 50 con Cassetto_Cassetti / with Drawer_Drawers **P. 36,5 - 45,5 - 50**

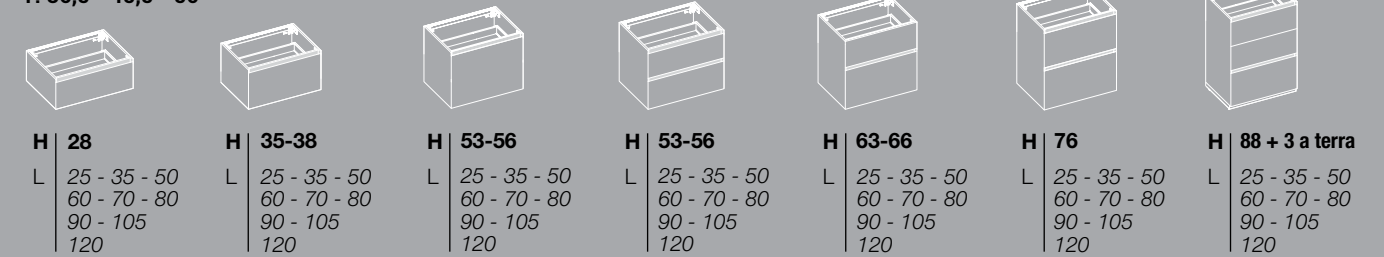

Basi Lavabo / Washbasin base units con 2 Ante / with 2 doors **P. 36,5 - 45,5 - 50**

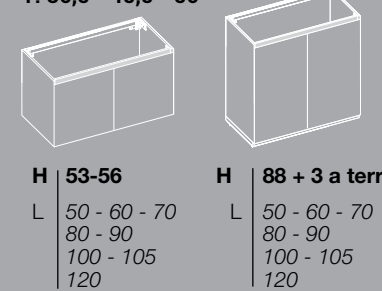

Basi / Base units con 1 Anta / with 1 door **P. 36,5 - 45,5 - 50**

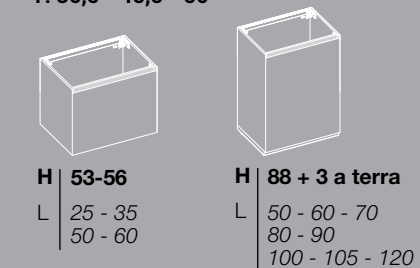

Basi / Base units con 2 Ante / with 2 doors **P. 50 - 62 - 68 - 78**

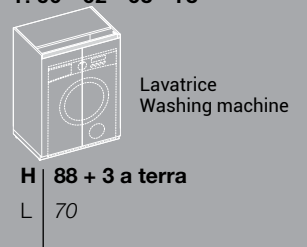

Pensili / Wall Units con 1 Anta - 2 Ante / with 1 door - 2 doors **P. 21 - 27 - 36,5**

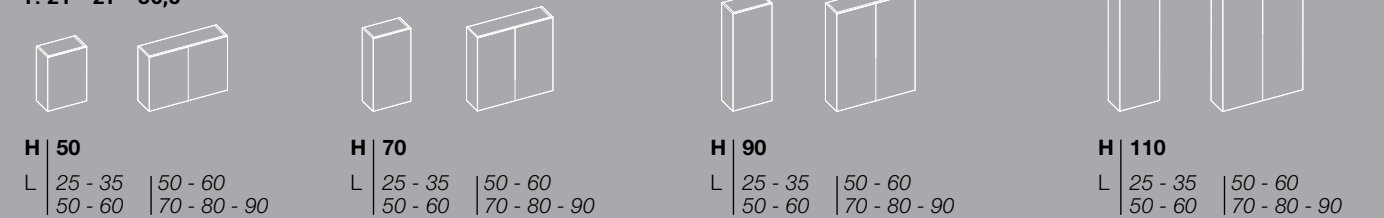

Colonne / Columns con 1 Anta / with 1 door **P. 21 - 27 - 36,5 - 50**

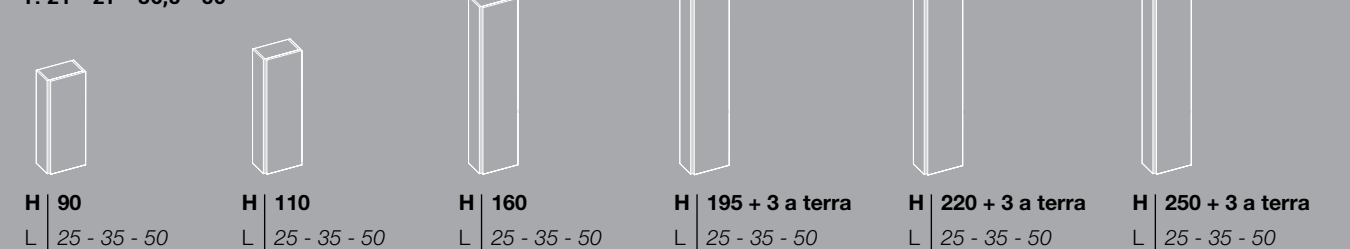

Modularità Sistema Wally

Wally M3 System Modularity
 Modularité du Système Wally M3
 Wally M3 Systemmodularität
 Modularidad del Sistema Wally M3

Elemento Sinistro
Left element

Elemento Centrale
Central element

Elemento Destro
Right element

Elemento Singolo
Single element

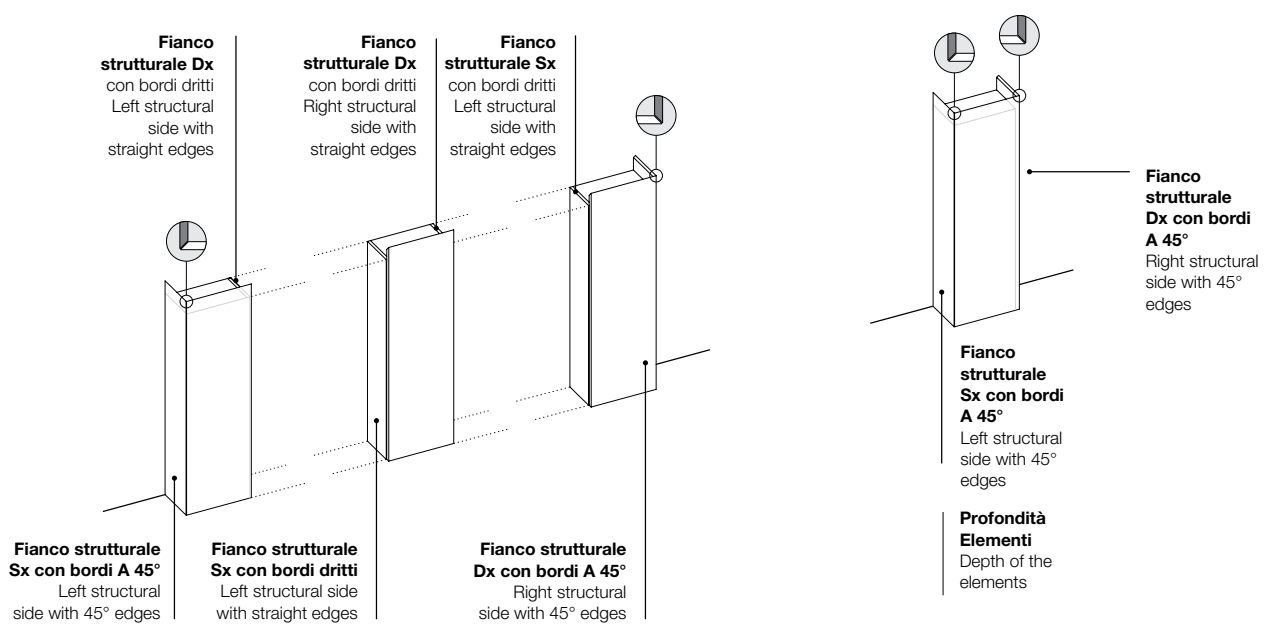

___Ogni sistema presuppone, variabili e combinazioni, in questa pagina la modularità di Wally evidenzia l'ampia gamma di possibilità e dimensioni. ___ Every system presupposes, variables and combinations, on this page Wally's modularity highlights the wide range of possibilities and dimensions. ___ Chaque système présuppose variables et combinaisons, sur cette page la modularité de Wally met en évidence le large éventail de possibilités et de tailles. ___ Jedes System setzt Variablen und Kombinationen voraus, auf dieser Seite hebt die Modularität von Wally die breite Palette an Möglichkeiten und Dimensionen hervor. ___ Todo sistema presupone, variables y combinaciones, en esta página la modularidad de Wally pone de manifiesto la amplia gama de posibilidades y dimensiones.

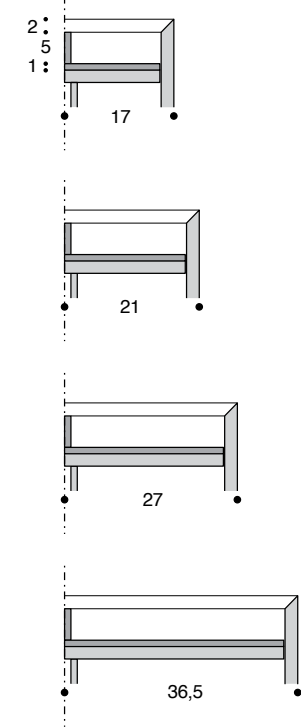

Elementi a terra / Floor-standing elements

P. 17 - 21 - 36,5

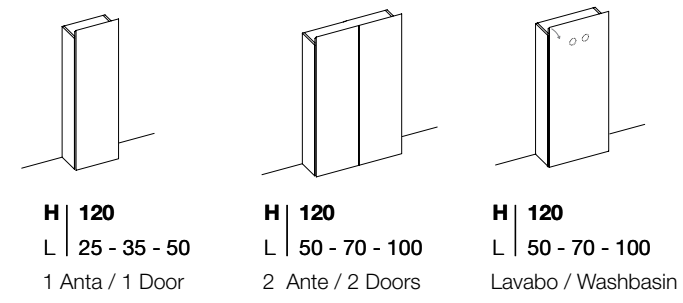

Elementi sospesi / Wall-mounted elements

P. 17 - 21 - 36,5

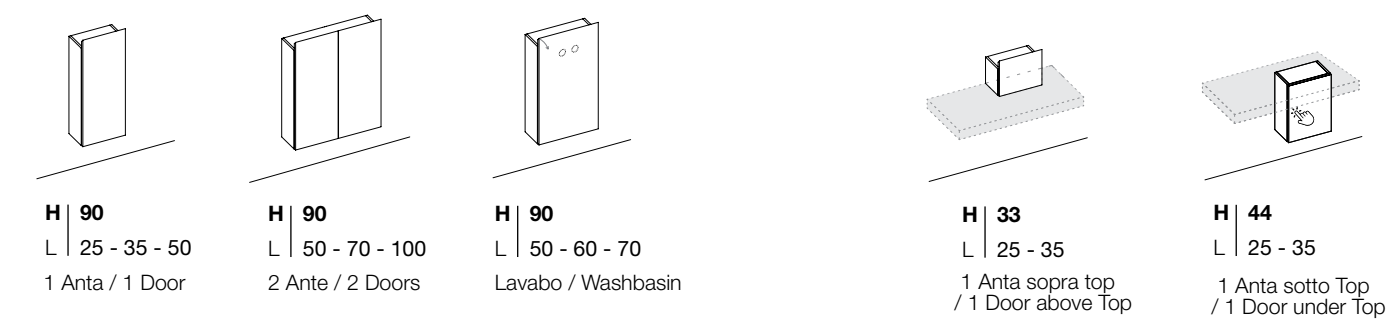

Elemento pensile / Wall unit

P. 17 - 21 - 36,5

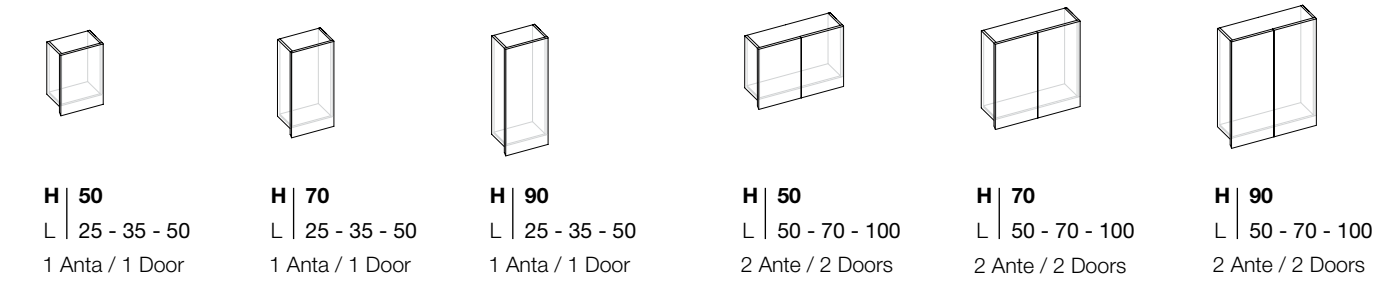

Elemento angolo a terra / Floor-Standing base unit suitable for corners

P. 17 - 21 - 36,5

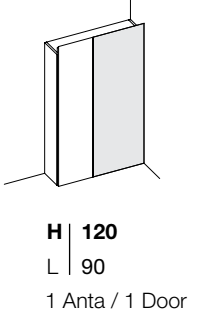

Elemento angolo sospeso / Wall-Mounted base unit suitable for corners

P. 17 - 21 - 36,5

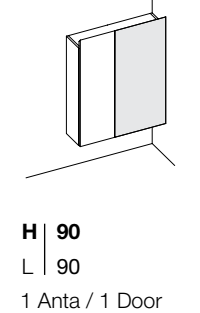

Elemento Pensile sopra angolo / Wall Unit suitable for corners

P. 17 - 21 - 36,5

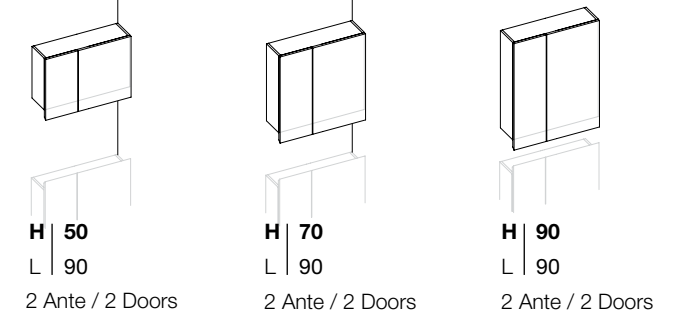

M₃ System

Mobili P. 45,5
Furniture P. 45,5

Top con vasca integrata

Top with integrated washbasin

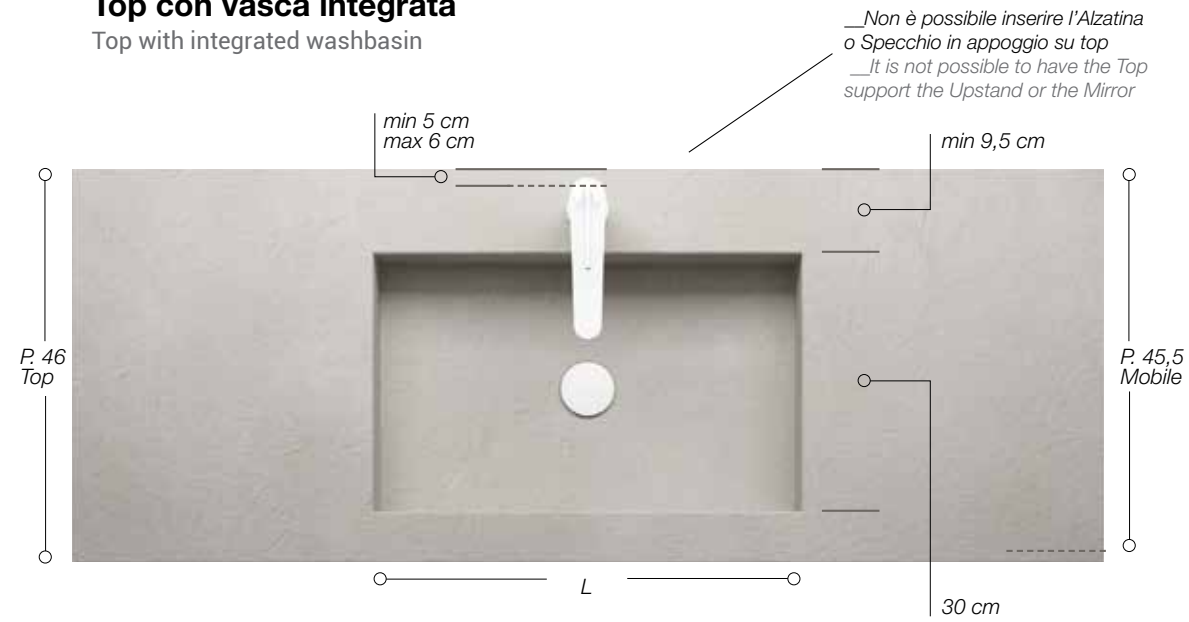

* Esempio Base con Top in Gres con vasca integrata Prisma 30 x 50
* Example Base Unit with Gres Top and Prisma integrated Washbasin 30 x 50

Top con lavabo tutt fuori

Top with sit-on Washbasin

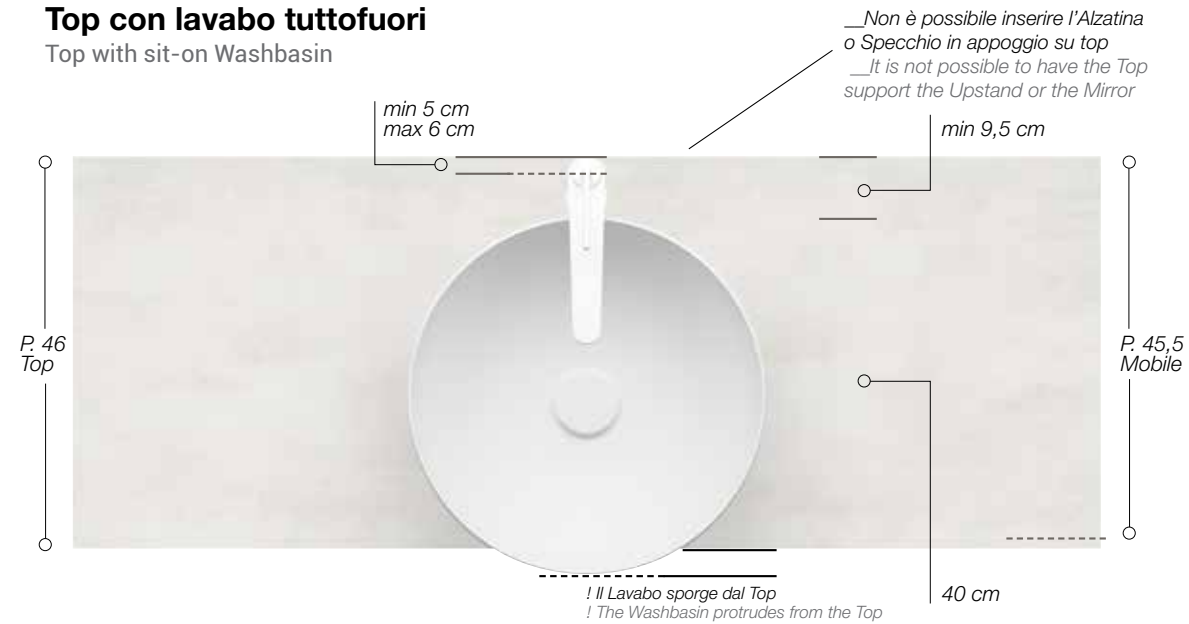

* Esempio Base con Top in Dekorativo 3D e Lavabo Tutt fuori Blade 06 in Ceramica Ø 40
* Example Base Unit with Top in Dekorativo 3D and Blade 06 ceramic Sit-on Washbasin Ø 40

Mobili P. 50 cm
Furniture P. 50 cm

Top con vasca integrata

Top with integrated washbasin

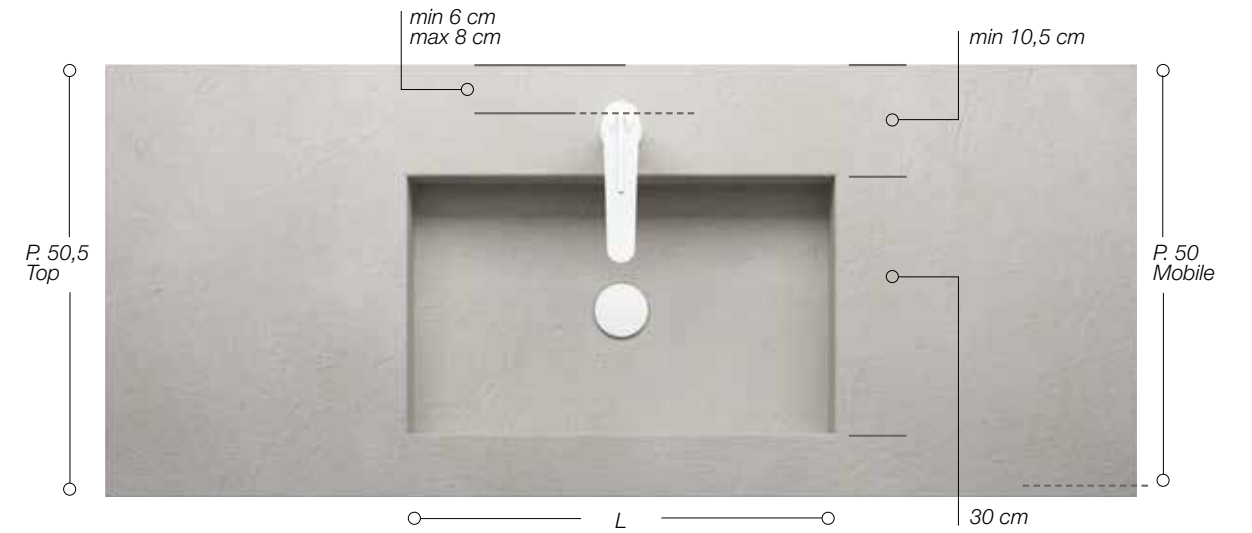

* Esempio Base con Top in Gres con vasca integrata Prisma 30 x 50
* Example Base Unit with Gres Top and Prisma integrated Washbasin 30 x 50

Top con lavabo tutt fuori

Top with sit-on Washbasin

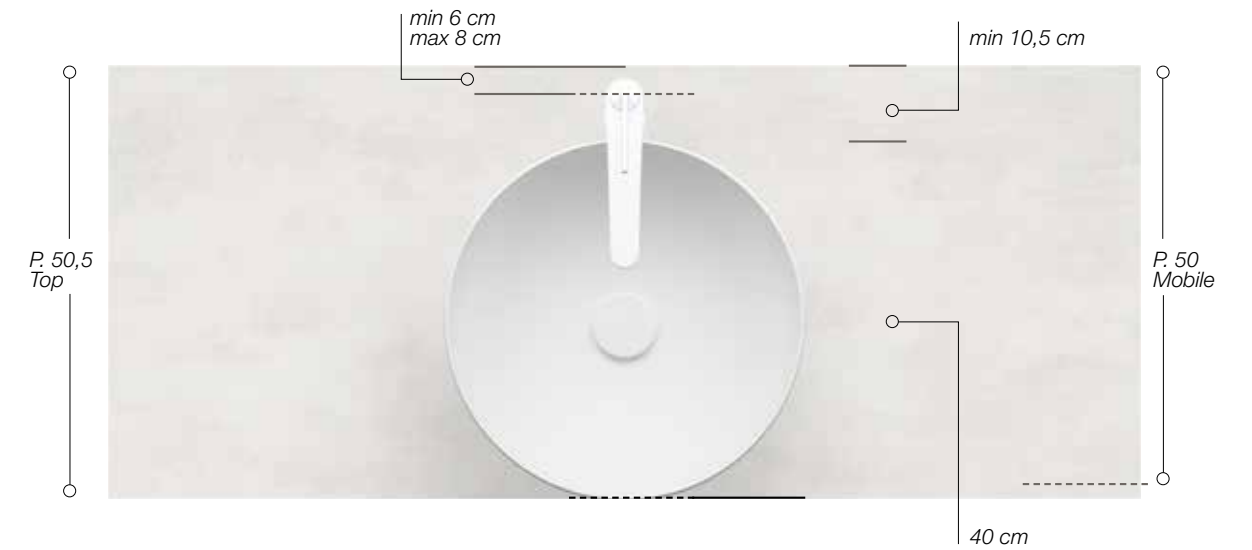

* Esempio Base con Top in Dekorativo 3D e Lavabo Tutt fuori Blade 06 in Ceramica Ø 40
* Example Base Unit with Top in Dekorativo 3D and Blade 06 ceramic Sit-on Washbasin Ø 40

M3 System

Attrezzatura interna

Internal equipment
Aménagements intérieurs
Innenausstattungen
Equipo interno



Separatori in metallo verniciato Grigio Stone disponibili in 3 differenti larghezze per organizzare lo spazio di tutte le basi con cassetto, realizzati in 2 profondità per adattarsi alle Basi profonde 45,5 e 50 cm. ____ Grigio Stone painted metal dividers available in 3 different widths to organise the space of all base units with drawer, made in 2 depths to fit 45.5 and 50 cm deep base units ____ Séparateurs en métal peint Grigio Stone disponibles en 3 largeurs différentes pour organiser l'espace de tous les éléments bas avec tiroir, fabriqués en 2 profondeurs pour s'adapter aux éléments bas de 45,5 et 50 cm de profondeur. ____ Trennwände aus Metall, Grigio Stone lackiert, erhältlich in 3 verschiedenen Breiten, um den Raum aller Unterschränke mit Schublade zu organisieren, hergestellt in 2 Tiefen, passend für Unterschränke mit 45,5 und 50 cm Tiefe ____ Separadores metálicos pintados en Grigio Stone disponibles en 3 anchos diferentes para organizar el espacio de todas las bases con cajón, fabricados en 2 profundidades para adaptarse a las profundidades de las Bases de 45,5 y 50 cm.

Per Basi Cassetto P 45.5

____ For Base Units With Drawers D. 45,5
____ Pour Éléments Bas Avec Tiroirs P. 45,5
____ Für Unterschränke Mit Schubladen T.45,5
____ Para Bases Con Cajones P.45,5

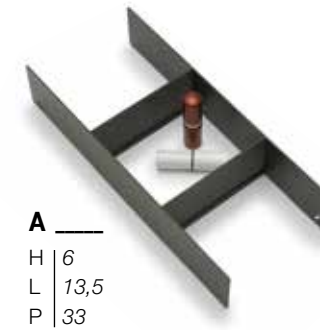

A ____
H | 6
L | 13,5
P | 33

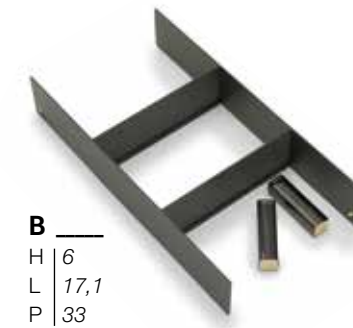

B ____
H | 6
L | 17,1
P | 33

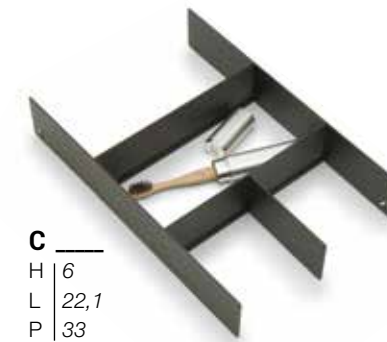

C ____
H | 6
L | 22,1
P | 33

Per Basi Cassetto P 50

____ For Base Units With Drawers D. 50
____ Pour Éléments Bas Avec Tiroirs P. 50
____ Für Unterschränke Mit Schubladen T.50
____ Para Bases Con Cajones P.50

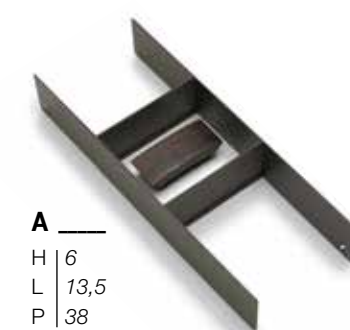

A ____
H | 6
L | 13,5
P | 38

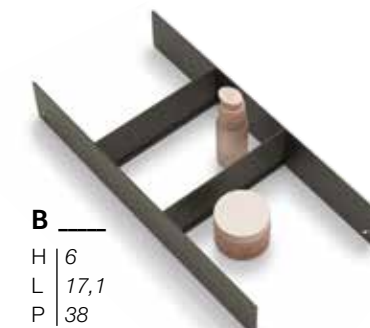

B ____
H | 6
L | 17,1
P | 38

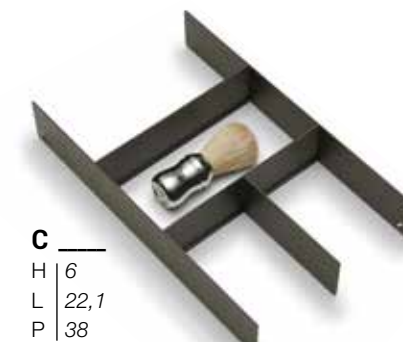

C ____
H | 6
L | 22,1
P | 38

M3 System

Attrezzatura interna

Internal equipment
Aménagements intérieurs
Innenausstattungen
Equipo interno

Per Basi Cassetto P 45,5 / 50

For base units with drawers D. 45,5 / 50 ___ Pour éléments bas avec tiroirs P. 45,5 / 50
Für unterschränke mit schubladen T.45,5 / 50 ___ Para bases con cajones P.45,5 / 50



A
H | 6
L | 13,5
P | 33 - 38



C
H | 6
L | 22,1
P | 33 - 38

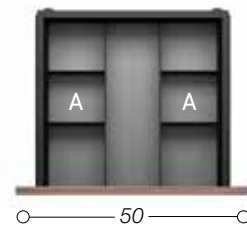

A
H | 6
L | 13,5
P | 33 - 38

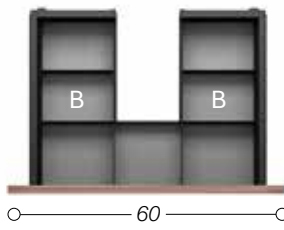

B
H | 6
L | 17,1
P | 33 - 38

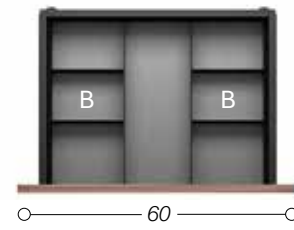

B
H | 6
L | 17,1
P | 33 - 38

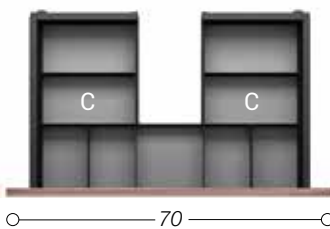

C
H | 6
L | 22,1
P | 33 - 38

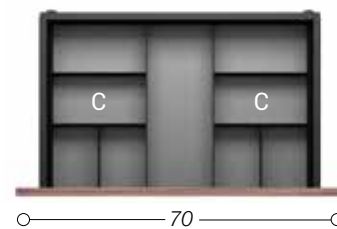

C
H | 6
L | 22,1
P | 33 - 38



___ Le attrezzature interne si abbinano cromaticamente alle sponde in metallo grigio stone del cassetto con fondo ad effetto pell in tinta e possono essere utilizzate anche per suddividere gli spazi dei cassetti con fondo sagomato per assecondare il passaggio del sifone sotto lavabo. ___ The interior fittings match chromatically to the Grigio Stone metal drawer sides with matching leather-effect bottom and can also be used to divide the space of the drawers with contoured bottom to accommodate the under-basin siphon. ___ Les aménagements intérieurs sont assortis à la couleur des côtés des tiroirs en métal Grigio Stone avec un fond assorti effet cuir et peuvent également être utilisés pour diviser l'espace des tiroirs avec découpe siphon pour accueillir le siphon sous vasque. ___ Die Innenausstattung ist farblich auf die Grigio Stone Metallseiten mit passendem Boden in Ledereffekt abgestimmt und kann auch zur Raumaufteilung der Schubladen mit Formboden zur Aufnahme des Untertischsiphons verwendet werden. ___ Los equipamientos interiores hacen juego con los laterales de los cajones de metal de color Grigio Stone con fondo de efecto cuero a juego y también pueden utilizarse para dividir los espacios de los cajones con fondo perfilado para alojar el sifón bajo el lavabo.

M3 System

Attrezzatura interna

Internal equipment
Aménagements intérieurs
Innenausstattungen
Equipo interno

Per Basi Cassetto P 45,5 / 50

For base units with drawers D. 45,5 / 50 ____ Pour éléments bas avec tiroirs P. 45,5 / 50
Für unterschränke mit schubladen T.45,5 / 50 ____ Para bases con cajones P.45,5 / 50

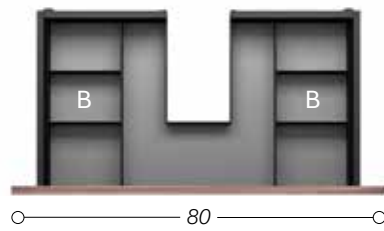

B
H | 6
L | 17,1
P | 33 - 38

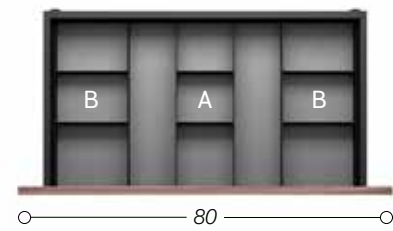

B **A**
H | 6 H | 6
L | 17,1 L | 13,5
P | 33 - 38 P | 33 - 38

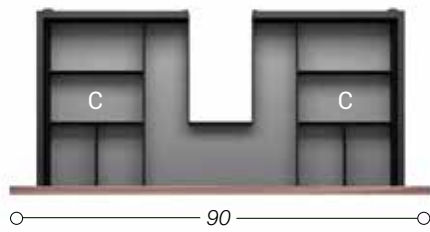

C
H | 6
L | 22,1
P | 33 - 38

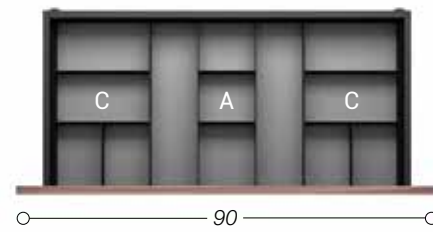

C **A**
H | 6 H | 6
L | 22,1 L | 13,5
P | 33 - 38 P | 33 - 38

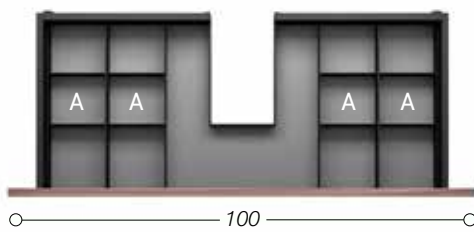

A
H | 6
L | 13,5
P | 33 - 38

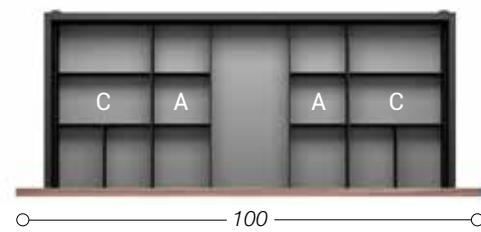

C **A**
H | 6 H | 6
L | 22,1 L | 13,5
P | 33 - 38 P | 33 - 38



M3 System

Attrezzatura interna

Internal equipment
Aménagements intérieurs
Innenausstattungen
Equipo interno

Per Basi Cassetto P 45.5 / 50

For base units with drawers D. 45,5 / 50 ___ Pour éléments bas avec tiroirs P. 45,5 / 50
Für unterschränke mit schubladen T.45,5 / 50 ___ Para bases con cajones P.45,5 / 50

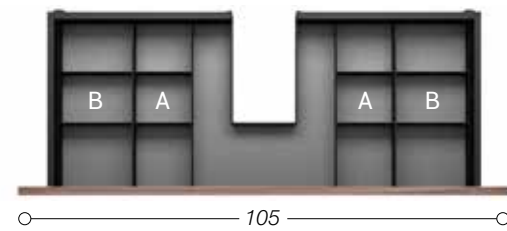

B	A
H 6	H 6
L 17,1	L 13,5
P 33 - 38	P 33 - 38

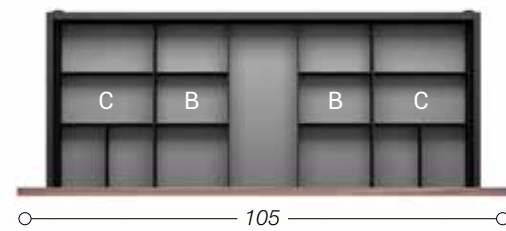

C	B
H 6	H 6
L 22,1	L 17,1
P 33 - 38	P 33 - 38

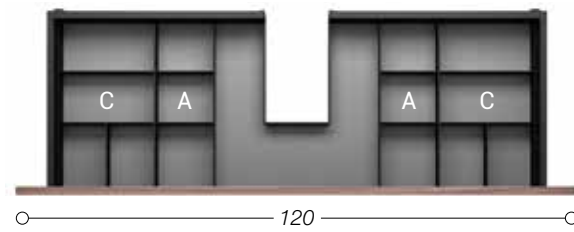

C	A
H 6	H 6
L 22,1	L 13,5
P 33 - 38	P 33 - 38

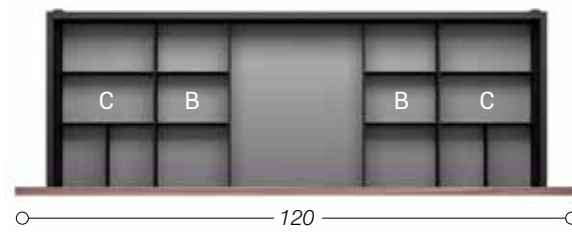

C	B
H 6	H 6
L 22,1	L 17,1
P 33 - 38	P 33 - 38

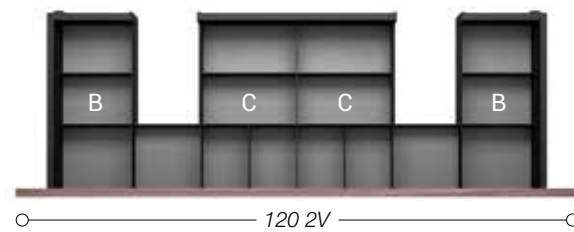

B	C
H 6	H 6
L 17,1	L 22,1
P 33 - 38	P 33 - 38



M3 System

Legenda elementi e materiali

Elements key and materials
Légende des éléments et matériaux
Legende Elemente und Materialien
Leyenda elementos y materiales

01 Base

Base unit
Élément bas
Unterschrank
Base

02 Base a giorno

Open compartment
Élément ouvert
Offenes Fach
Elemento abierto

03 Gola

Groove
Gorge
Griffmulde
Gola

04 Top

Top
Plan de toilette
Waschtischplatte
Encimera

05 Lavabo

Washbasin
Vasque
Waschbecken
Lavabo

06 Pensile/Colonna

Wall unit . Tall unit
Élément haut . Colonne
Hängeelement . Hochschrank
Colgante . Columna

07 Pensile a giorno

Open wall unit
Élément haut ouvert
Offenes Hängeelement
Colgante abierto

08 Specchio

Mirror
Miroir
Spiegel
Espejo

09 Lampada

Light
Lampe
Lampe
Lámpara

10 Accessori

Accessories
Accessoires
Zubehör
Accesorios

M3 System

__technical data

La modularità della linea Baxar è pensata per offrire un'ampia scelta di componenti combinabili in diverse forme e finiture, per creare la tua composizione del relax.

___ The modularity of the Baxar range is designed to offer a wide choice of components that can be combined in different shapes and finishes to create your own relaxation composition.

___ La modularité de la gamme Baxar est conçue pour offrir un large choix de composants qui peuvent être combinés dans différentes formes et finitions pour créer votre propre composition de relaxation.

___ Der modulare Aufbau der Baxar-Reihe bietet eine große Auswahl an Komponenten, die in verschiedenen Formen und Ausführungen kombiniert werden können, um Ihre eigene Entspannungskomposition zu schaffen.

___ La modularidad de la gama Baxar está pensada para ofrecer una amplia gama de componentes que pueden combinarse con diferentes formas y acabados para crear su propia composición de relajación.

M₃ System

C 301 pages 06-13

05 | Lavabo a Terra OLIVER L. 48 P. 38 H. 87 cm Cristalplant Bianco opaco (TNB), verniciato esterno Grigio Londra (2FD) ___ Floor-standing washbasin OLIVER W. 48 D. 38 H. 87 cm Cristalplant Bianco opaque (TNB), painted exterior Grigio Londra (2FD) ___ Vasque au sol OLIVER L. 48 P. 38 H. 87 cm Cristalplant Bianco mat (TNB), peinture extérieure Grigio Londra (2FD) ___ Standwaschtisch OLIVER B. 48 T. 38 H. 87 cm Cristalplant Bianco matt (TNB), außen lackiert Grigio Londra (2FD) ___ Lavabo al suelo OLIVER A. 48 P. 38 Alt. 87 cm Cristalplant Bianco opaco (TNB), pintado exterior Grigio Londra (2FD)

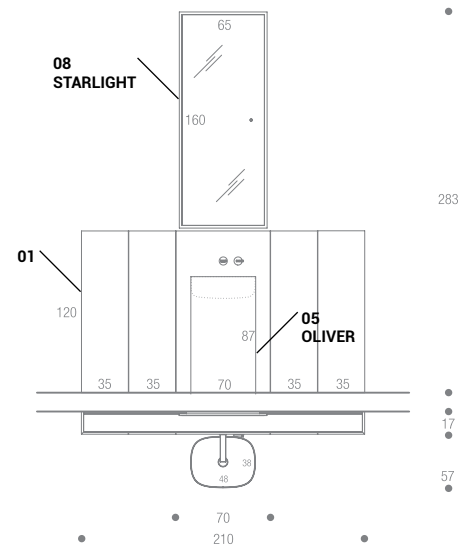

_01 Laccato Torba opaco (2DS) Cannelé verticale Tipo B
_05 Grigio Londra (2FD)
_05 Cristalplant bianco opaco (TNB)

M₃ System

C 302 pages 14-23

05 | Lavabo ASCOT H. 29,7 L. 80 cm Gres Calacatta Oro Venato opaco (TQW) ___ASCOT washbasin H. 29,7 W. 80 cm Gres Matt Calacatta Oro Venato (TQW) ___Vasque ASCOT H. 29,7 L. 80 cm Grés Cérame Calacatta Oro Venato opaco (TQW) ___ASCOT Waschtisch H. 29,7 B. 80 cm Gres Calacatta Oro Venato matt (TQW) ___Lavabo ASCOT L. 29,7 L. 80 cm Gres Mate Calacatta Oro Venato (TQW)

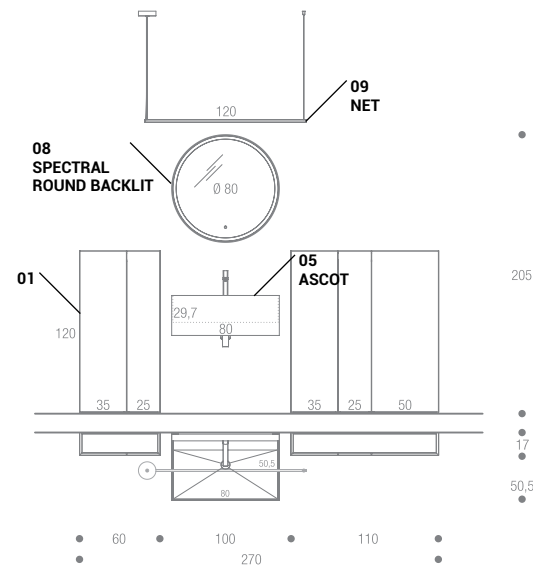

_01 Impiallacciato Rovere Sabbia (06C)
_05 Gres Calacatta Oro Venato opaco (TQW)
_08_09 Metallo Verniciato nero opaco (203)

M₃ System

C 303 pages 26-35

04 | Top Sp. 1,2 cm con vasca integrata Strip L. 57,5 cm HPL Rox Black (TKQ) ___1.2 cm thick top with integrated Strip W 57,5 cm HPL Rox Black (TKQ) ___Plan vasque Ep. 1,2 cm avec vasque intégrée Strip L.57,5 cm HPL Rox Black (TKQ) ___1,2 cm starke Waschtischplatte mit integriertem Strip Waschbecken B. 57,5 cm HPL Rox Black (TKQ) ___Encimera de 1,2 cm de grosor con lavabo integrado L. 57,5 cm HPL Rox Black (TKQ)

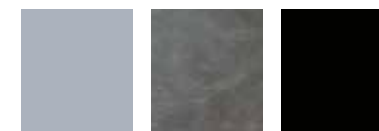
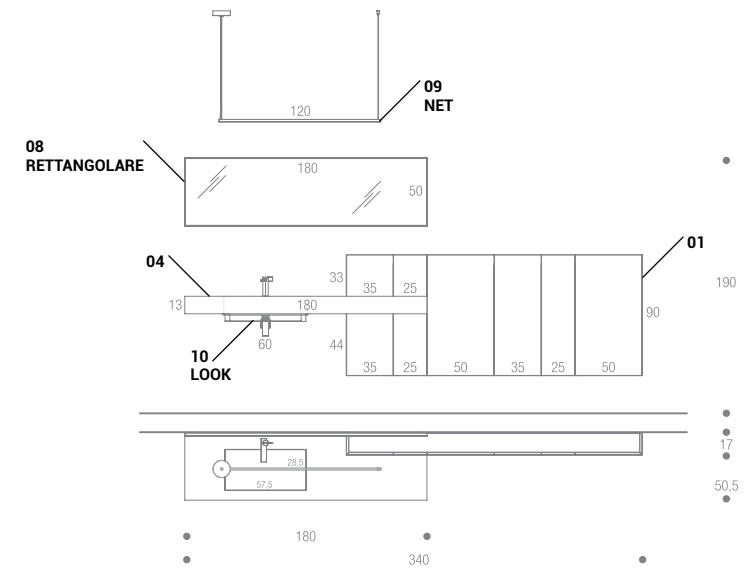

_01_06 Laccato Carta Da Zucchero opaco (247)
_04 HPL Rox Black (TKQ)
_09_10 Metallo Verniciato nero opaco (203)

M₃ System

C 304 pages 36-45

04 | Top Impiallacciato Rovere Fumo (06F) ___Impiallacciato Rovere Fumo Top (06F) ___Plan vasque en bois plaqué Rovere Fumo (06F) ___Furnierplatte Rovere Fumo (06F) ___Encimera Impiallacciato Rovere Fumo (06F)
05 | Lavabo Tutto Fuori FIVE 02 L. 48 P. 38 Cristalplant Bianco opaco (TNB), verniciato esterno Verde Salvia (242) ___All Outside washbasin FIVE 02 W. 48 D. 38 Cristalplant White matt (TNB), painted outside Verde Salvia (242) ___Vasque à poser FIVE 02 L. 48 P. 38 Cristalplant Bianco mat (TNB), peinture extérieure Verde Salvia (242) ___Aufsatzbecken FIVE 02 B. 48 T. 38 Cristalplant Weiß matt (TNB), außen lackiert Verde Salvia (242) ___Todos Lavabo exterior FIVE 02 L. 48 F. 38 Cristalplant Blanco mate (TNB), pintado exterior Verde Salvia (242)

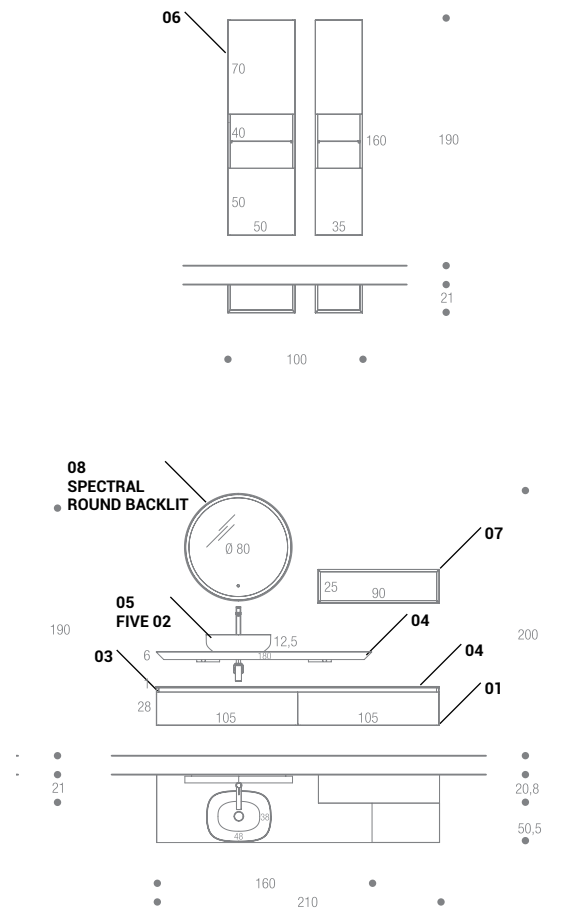

_01 Laccato Verde Salvia opaco (242) Cannelé orizzontale Tipo A
_03_07 Laccato Verde Salvia opaco (242)
_04_06 Impiallacciato Rovere Fumo (06F)
_08 Metallo Verniciato nero opaco (203)

M₃ System

C 305 pages 48-57

04 | Top Sp. 1,2 cm vasca integrata Trip L. 50 cm Tekcolor matt Terra (HDB) ___Top Thickness 1.2 cm Trip integrated basin W. 50 cm Tekcolor matt Terra (HDB) ___Plan vasque Ep. 1,2 cm avec vasque intégrée Trip L. 50 cm Tekcolor matt Terra (HDB) ___1,2 cm starke Waschtischplatte mit integriertem Trip Waschbecken B. 50 cm Tekcolor matt Terra (HDB) ___Encimera Grosor 1,2 cm Lavabo Trip integrado L. 50 cm Tekcolor mate Terra (HDB)

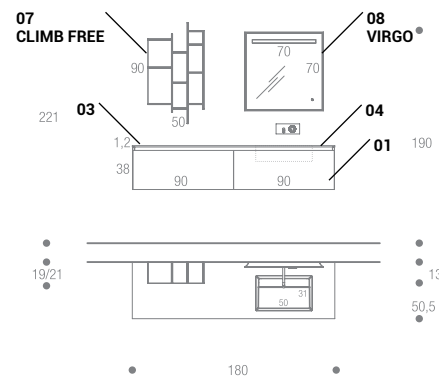
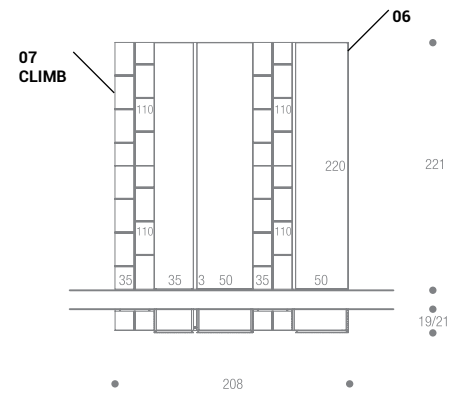

_01_06 Laccato Terra opaco (2DB)
Canneté verticale Tipo A
_03_07 Laccato Terra opaco (2DB)
_04 Tekcolor matt Terra (HDB)
_07 Dekorativo 3 D Castagno malto (1C2)
_08 Metallo verniciato Nero opaco (203)

M₃ System

C 306 pages 58-67

04 | Top Sp. 1,2 cm con doppia vasca integrata Quadra L. 60 cm Gelcolor matt Grigio Luce (G07) ___1.2 cm thick worktop with integrated Quadra double basin W. 60 cm Gelcolor matt Grigio Luce (G07) ___Plan vasque Ep. 1,2 cm avec double vasque intégrée Quadra L. 60 cm Gelcolor matt Grigio Luce (G07) ___1,2 cm starke Waschtischplatte mit integriertem Quadra Waschbecken B. 60 cm Gelcolor matt Grigio Luce (G07) ___Encimera de 1,2 cm de grosor con lavabo doble Quadra integrado L. 60 cm Gelcolor mate Grigio Luce (G07)

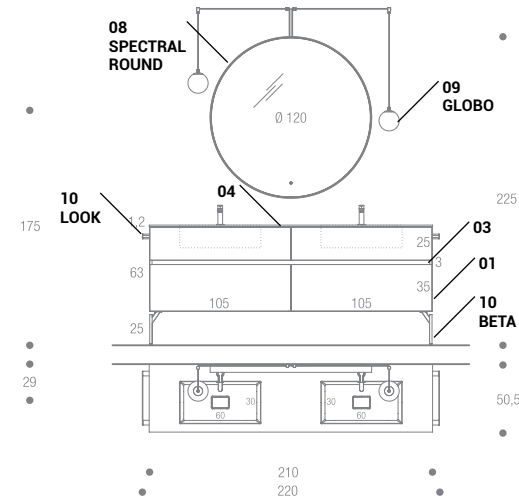
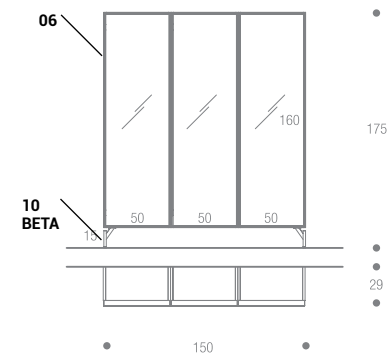

_01 Laccato Grigio Luce opaco (207)
Tipo B
_03 Laccato Grigio Luce opaco (207)
_04 Gelcolor matt Grigio Luce (G07)
_06_08_09_10 Metallo verniciato nero opaco (203)
_06 Vetro stop-sol grigio (04K)

M₃ System

C 306 Var pages 68-69

04 | Top Sp. 1,2 cm con doppia vasca integrata Quadra L. 60 cm Gelcolor matt Grigio Luce (G07) ___1.2 cm thick worktop with integrated Quadra double basin W. 60 cm Gelcolor matt Grigio Luce (G07) ___Plan vasque Ep. 1,2 cm avec double vasque intégrée Quadra L. 60 cm Gelcolor matt Grigio Luce (G07) ___1,2 cm starke Waschtischplatte mit integriertem Quadra Doppelwaschtischbecken B. 60 cm Gelcolor matt Grigio Luce (G07) ___Encimera de 1,2 cm de grosor con lavabo doble Quadra integrado L. 60 cm Gelcolor mate Grigio Luce (G07)

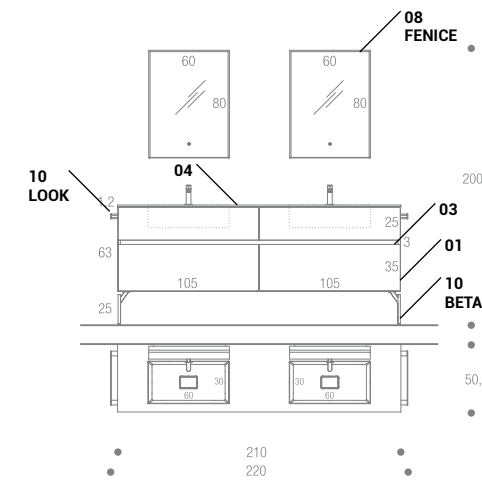

_01 Laccato opaco Grigio Luce (207)
_03 Laccato opaco Nero (203)
_04 Gelcolor matt Grigio Luce (G07)
_08_10 Alluminio/metallo verniciato Nero opaco (203)

M₃ System

C 307 pages 70-81

04 | Top Sp. 1 cm con vasca integrata Scivolo L. 70 cm Gres Pietra Piasentina Grigia (TQP) ___Top Th. 1 cm with Scivolo integrated washbasin W. 70 cm, Gres Pietra Piasentina Grigia (TQP) ___Plan Ép. 1 cm avec vasque intégrée Scivolo L. 70, Grès Pietra Piasentina Grigia (TQP) ___Platte St. 1 cm mit integriertem Waschbecken Scivolo B.70 cm, Gres Pietra Piasentina Grigia (TQP) ___ Encimera Esp. 1 cm con lavabo integrado Scivolo L.70 cm, Gres Pietra Piasentina Grigia (TQP)

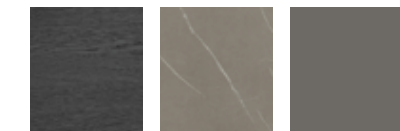
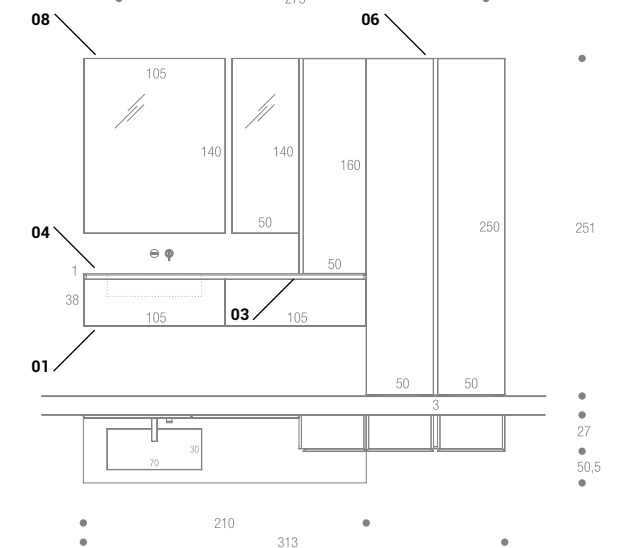
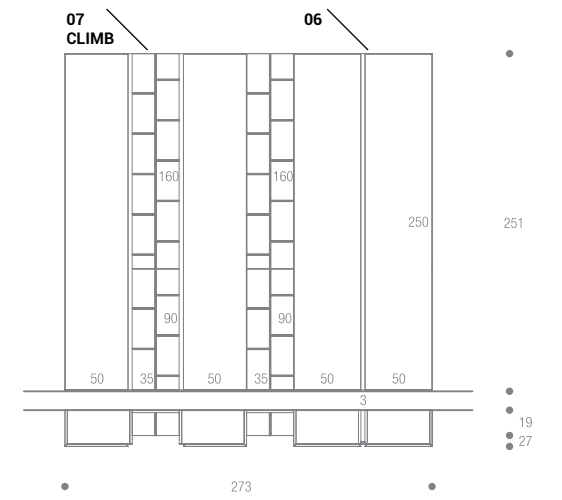

_01_03_07 Impialliato Rovere Nero (06J)
_04 Gres Pietra Piasentina Grigia (TQP)
_06_07 Laccato opaco Grigio Londra (2FD)

M₃ System

C 308

pages 84-95

05 | Lavabo ASCOT H. 29,7 L. 90 cm Gres Pietra Piasentina Taupe (TQQ) ___Ascot Washbasin H. 29,7 W. 90 cm Gres Pietra Piasentina Taupe (TQQ) ___Vasque Ascot H. 29,7 L. 90 cm en Grès Pietra Piasentina Taupe (TQQ) ___Washbecken Ascot H. 29,7 B. 90 cm Gres Pietra Piasentina Taupe (TQQ) ___Lavabo Ascot H. 29,7 L. 90 cm en Gres Pietra Piasentina Taupe (TQQ)

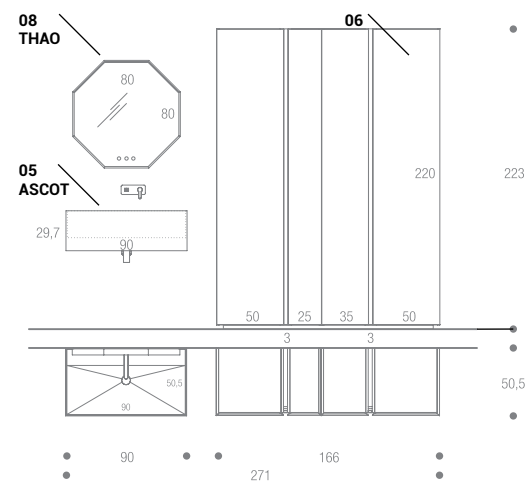

_05
Gres Pietra Piasentina Taupe (TQQ)

_06
Impiallacciato Rovere Sabbia (06C)

_08
Alluminio verniciato Nero opaco (203)

M₃ System

C 309

pages 96-111

04 | Top Sp. 1 cm con vasca integrata Prisma L. 70 cm Gres Sahara Noir Silky (TR8) ___Top Th. 1 cm with Prisma integrated washbasin W.70 cm, Gres Sahara Noir Silky (TR8) ___Plan Ép. 1 cm avec vasque intégrée Prisma L. 70 cm, Grès Sahara Noir Silky (TR8) ___Platte St. 1 cm mit integriertem Waschbecken Prisma B.70 cm, Gres Sahara Noir Silky (TR8) ___Encimera Esp. 1 cm con lavabo integrado Prisma L.70 cm, Gres Sahara Noir Silky (TR8)

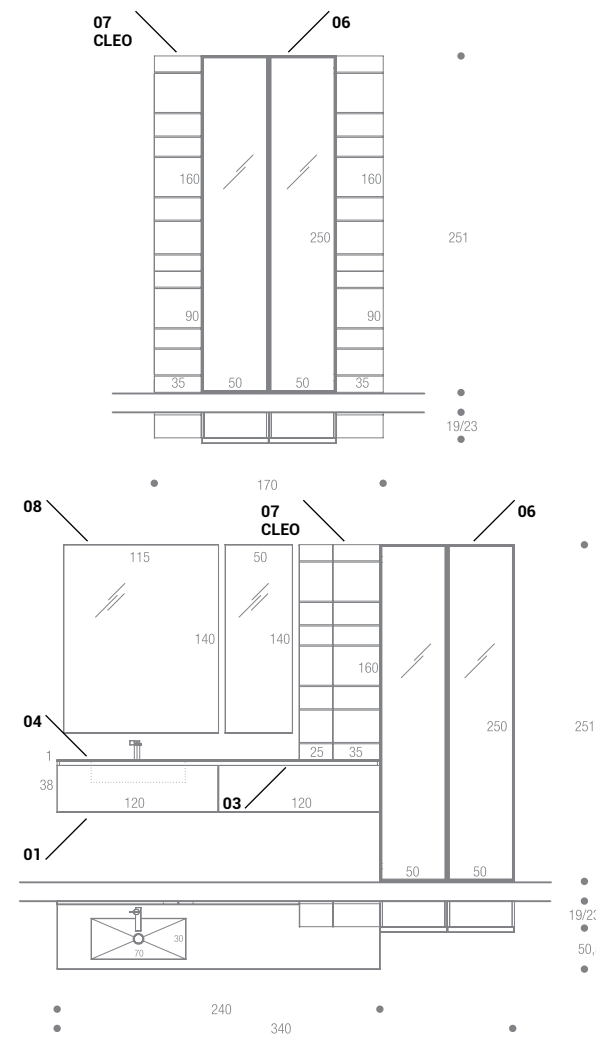

_01_03_07
Impiallacciato Eucalipto Affumicato (01A)

_04
Gres Sahara Noir Silky (TR8)

_06_07
Alluminio/metallo verniciato Nero opaco (203)

_06
Vetro fumè (04F)

_07
Laccato opaco Nero (203)

M₃ System

C 310

pages 114-125

04 | Top Sp. 1 cm Impiallacciato Rovere Moka (06G) ___Top Th. 1 cm Rovere Moka veneered Wood (06G) ___FR Plan Ép. 1 cm plaqué Rovere Moka (06G) ___Platte St. 1 cm aus Rovere Moka (06G) Furnier ___Encimera Esp. 1 cm de enchapado de madera en Rovere Moka (06G)

05 | Lavabo Tutto Fuori BLADE 06 (Ø40 cm) Ceramica Cenere Opaca (OCE) ___BLADE 06 (Ø40 cm) Sit-on Washbasin in matt Cenere Ceramic (OCE) ___Vasque à poser BLADE 06 (Ø40 cm) en Céramique Cenere mate (OCE) ___Aufsatzbecken BLADE 06 (Ø40 cm) Cenere matt Keramik (OCE) ___Lavabo esterno BLADE 06 (Ø40 cm) Cerámica Cenere Opaca (OCE)

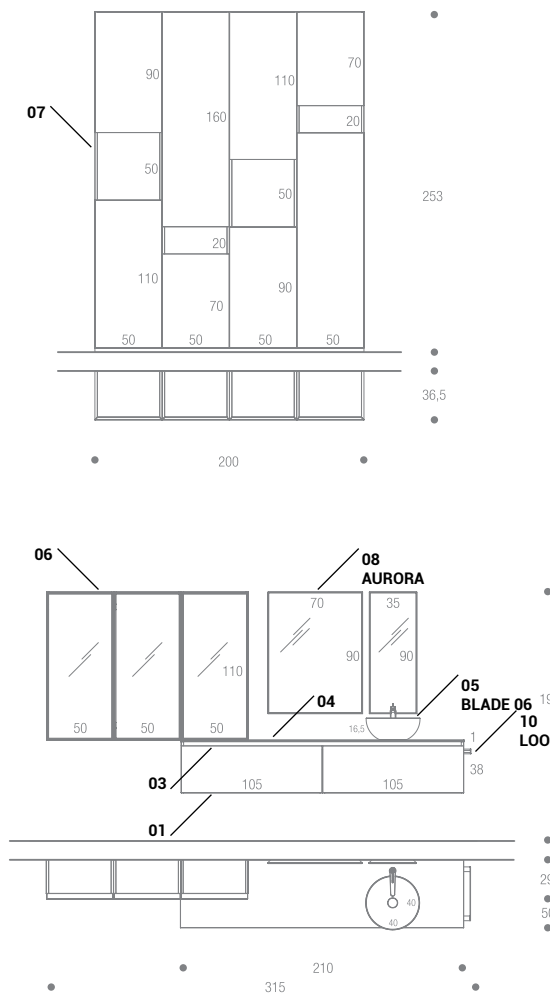

_01_03_04_07
Impiallacciato Rovere Moka (06H)

_05
Ceramica Cenere Opaca (OCE)

_06_10
Alluminio/metallo verniciato Creta opaco (2M6)

_06
Vetro stop-sol grigio (04K)

M₃ System

C 311

pages 126-137

04 | Top Sp. 6 cm con vasca integrata Prisma L. 60 cm Gres Pietra Grey (TQU) ___Top Th. 6 cm with Prisma integrated washbasin W. 60 cm, Gres Pietra Grey (TQU) ___Plan Ép. 6 cm avec vasque intégrée Prisma L. 60 cm, Grès Pietra Grey (TQU) ___Platte St. 6 cm mit integriertem Waschbecken Prisma B. 60 cm, Gres Pietra Grey (TQU) ___Encimera Esp. 6 cm lavabo integrado Prisma L. 60 cm, Gres Pietra Grey (TQU)

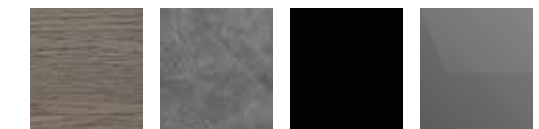
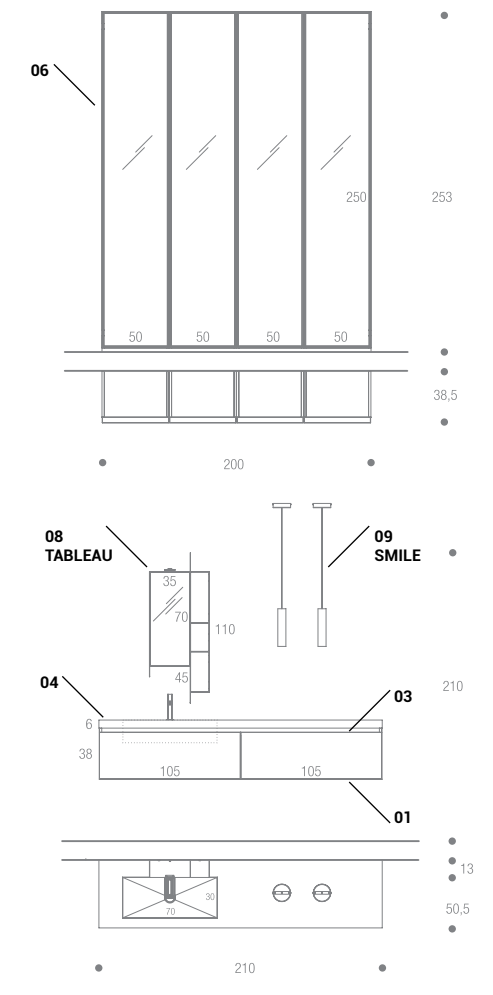

_01_03_08
Impiallacciato Rovere Cenere (06D)

_04
Gres Pietra Grey (TQU)

_06_08_09
Alluminio/metallo verniciato Nero opaco (203)

_06
Vetro fumè (04F)

M₃ System

C 312 pages 140-151

04 | Top Sp. 10 cm Dekorativo 3D Eucalipto Lab Affumicato (1E2)
 ___Top Th. 10 cm Dekorativo 3D Eucalipto Lab Affumicato (1E2)
 ___Plan Ép. 10 cm Dekorativo 3D Eucalipto Lab Affumicato (1E2)
 ___Platte St. 10 cm Dekorativo 3D Eucalipto Lab Affumicato (1E2)
 ___Encimera Esp. 10 cm Dekorativo 3D Eucalipto Lab Affumicato (1E2)

05 | Lavabo Tutto Fuori SMART B 05 - L.55 P. 45 cm Ceramica Bianco Opaco (OCB) ___SMART B 05 Sit-on Washbasin - W.55 P. 45 cm Matt White Ceramic (OCB) ___Vasque à poser SMART B 05 - L.55 P. 45 cm Céramique Blanche mate (OCB) ___Aufsatzbecken SMART B 05 - L.55 P. 45 cm matt Weiß Keramik (OCB) ___Lavabo externo SMART B 05 - L.55 P. 45 cm Cerámica Blanca Opaca (OCB)

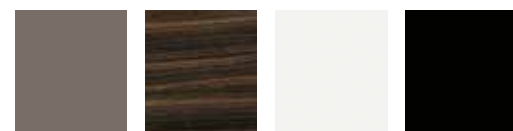
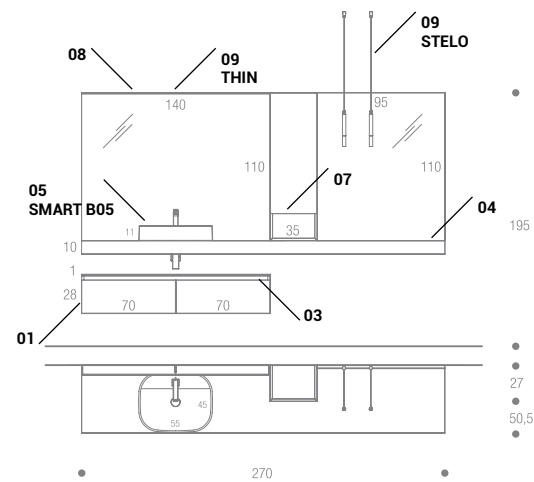

_01_03_07 Laccato opaco soft-touch Argilla (8DR)
_04 Dekorativo 3D Eucalipto Lab Affumicato (1E2)
_05 Ceramica Bianca Opaca (OCB)
_09 Metallo verniciato Nero opaco (203)

M₃ System

C 313 pages 154-163

04 | Top Sp. 1 cm Gres Limestone Deep (TRG) ___Top Th. 1 cm Gres Limestone Deep (TRG) ___Plan Ép. 1 cm Grès Limestone Deep (TRG) ___Platte St. 1 cm Gres Limestone Deep (TRG) ___Encimera Esp. 1 cm Gres Limestone Deep (TRG)

05 | Lavabo ASCOT H. 39,7 L. 90 cm Gres Limestone Deep (TRG) ___ASCOT Washbasin H. 39,7 W. 90 cm Gres Limestone Deep (TRG) ___Vasque intégrée ASCOT H. 39,7 L. 90 cm Grès Limestone Deep (TRG) ___Waschbecken ASCOT H. 39,7 L. 90 cm Gres Limestone Deep (TRG) ___Lavabo ASCOT H. 39,7 L. 90 cm Gres Limestone Deep (TRG)

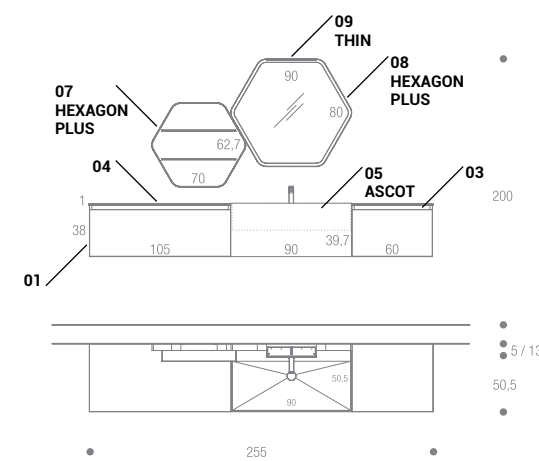

_01_03 Laccato opaco Grigio Lavagna (2A9)
_04_05 Gres Limestone Deep (TRG)
_07 Dekorativo 3D Noce Rigato Grigio (1N3)
_07_08 Metallo verniciato Carbone (243)
_08 Laccato opaco Carbone (243)

M₃ System

C 314 pages 164-171

04 | Lavamani THEO L. 60 cm Tecnoril Bianco Opaco (TT0) ___Hand-rinse Washbasin Theo W. 60 cm Tecnoril Bianco Matt (TT0) ___Lave-mains Theo L. 60 cm Tecnoril Bianco Mat (TT0) ___Hand-Waschbecken Theo L. 60 cm Tecnoril Bianco matt (TT0) ___Lavamanos Theo L. 60 cm Tecnoril Bianco Opaco (TT0)

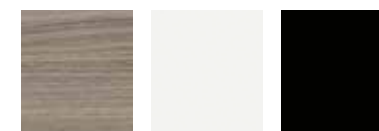
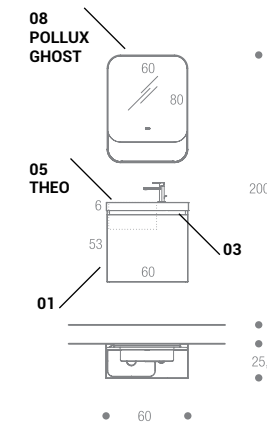

_01_03 Dekorativo 3D Noce Rigato Chiaro (1N1)
_05 Tecnoril Bianco Opaco (TT0)
_08 Alluminio verniciato Nero opaco (203)

M₃ System

C 315 pages 174-183

04 | Top Sp. 1,2 cm con vasca integrata Prisma L. 60 cm HPL Pulpis Chiaro (TKH) ___Top Th. 1,2 cm with Prisma integrated washbasin W. 60 cm HPL Pulpis Chiaro (TKH) ___Plan Ép. 1,2 cm avec vasque intégrée Prisma L. 60 cm HPL Pulpis Chiaro (TKH) ___Platte St. 1,2 cm mit integriertem Waschbecken Prisma L. 60 cm HPL Pulpis Chiaro (TKH) ___Encimera Esp. 1,2 cm con lavabo integrado Prisma L. 60 cm HPL Pulpis Chiaro (TKH)

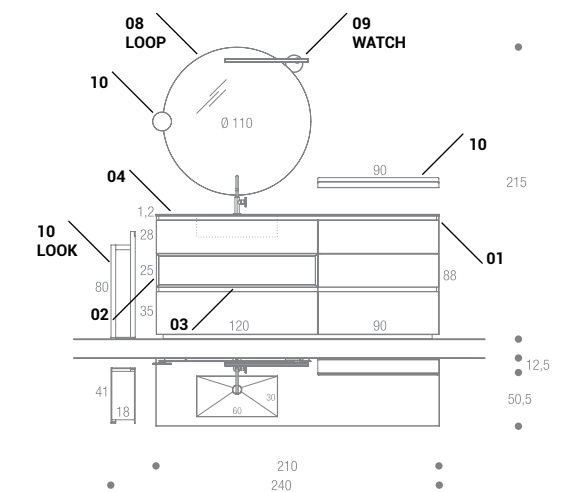

_01_03 Laccato opaco Canapa (294)
_02 Dekorativo 3D Noce Rigato Canaletto Naturale (1N2)
_04 HPL Pulpis Chiaro (TKH)
_09 Alluminio verniciato Nero opaco (203)
_10 Metallo verniciato Creta opaco (2M6)

M₃ System

C 316 pages 184-193

04 | Top Sp. 13 cm Deimos Stone Grigio Cemento (TTB) ___Top Th. 13 cm Deimos Stone Grigio Cemento (TTB) ___Plan Ép. 13 cm Deimos Stone Grigio Cemento (TTB) ___Platte St. 13 cm Deimos Stone Grigio Cemento (TTB) ___Encimera Esp. 13 cm Deimos Stone Grigio Cemento (TTB)

05 | Lavabo Tutto Fuori DREAM 04 (Ø48 cm) Ceramica Bianco Opaco (OCB) ___DREAM 04 Sit-on Washbasin (Ø 48 cm) matt White Ceramic ___Vasque à Poser DREAM 04 (Ø 48 cm) Céramique Blanche mat ___Aufsatzbecken DREAM 04 (Ø 48 cm) Keramik Weiß matt ___Lavabo externo DREAM 04 (Ø 48 cm) Cerámica Blanco Opaco

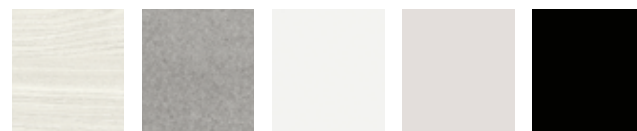
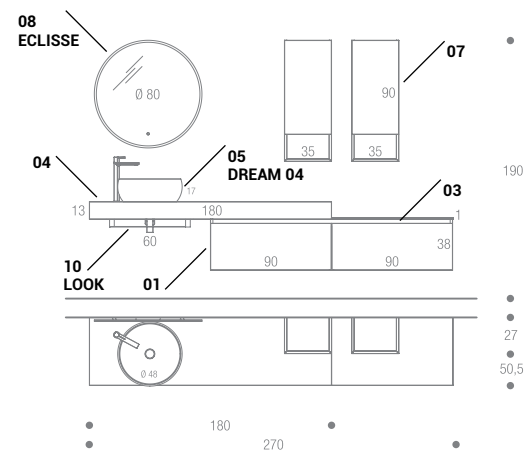

_01_03_07 Dekorativo 3D Castagno Chiaro (1C1)
_04 Deimos Stone Grigio Cemento (TTB)
_05 Ceramica Bianca Opaca (OCB)
_07 Laccato opaco Grigio Chiaro (2A8)
_10 Metallo verniciato Nero opaco (203)

M₃ System

C 317 pages 196-207

04 | Top Sp. 1 cm con vasca integrata Scivolo L. 70 cm Gres Calacatta Oro Venato (TQW) ___Top Th. 1 cm with Scivolo integrated washbasin W. 70 cm Gres Calacatta Oro Venato (TQW) ___Plan Ép. 1 cm avec vasque intégrée Scivolo L. 70 cm Grès Calacatta Oro Venato (TQW) ___Platte St. 1 mit integriertem Waschbecken Scivolo L. 70 cm Gres Calacatta Oro Venato (TQW) ___Encimera Esp. 1 cm con lavabo integrado Scivolo L. 70 cm Gres Calacatta Oro Venato (TQW)

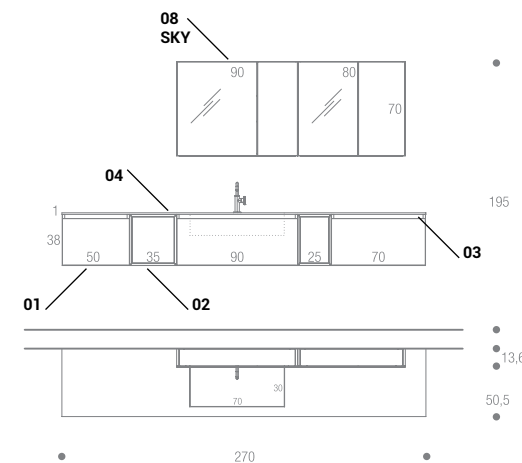

_01_03 Dekorativo 3D Eucalipto Lab Naturale (1E1)
_02 Laccato opaco Castoro Ottawa (2FC)
_04 Gres Calacatta Oro Venato (TQW)
_08 Laccato opaco Bianco (20B)

M₃ System

C 318 pages 208-213

04 | Top Sp. 1 cm Dekorativo 3D Castagno Scuro (1C3) ___Top Th. 1 cm Dekorativo 3D Castagno Scuro (1C3) ___Plan Ép. 1 cm Dekorativo 3D Castagno Scuro (1C3) ___Platte St. 1 cm Dekorativo 3D Castagno Scuro (1C3) ___Encimera Esp. 1 cm Dekorativo 3D Castagno Scuro (1C3)

05 | Lavabo Tutto Fuori SMART B02 L. 55 P. 38 Ceramica Bianco Opaco (OCB) ___SMART B 02 Sit-on Washbasin W. 55 P. 38 Matt White Ceramic ___Vasque à poser SMART B 02 L. 55 P. 38 Céramique Blanche Mate ___Aufsatzbecken SMART B 02 L. 55 P. 38 mattweißer Keramik ___Lavabo externo SMART B 02 L. 55 P. 38 Cerámica Blanca Opaca

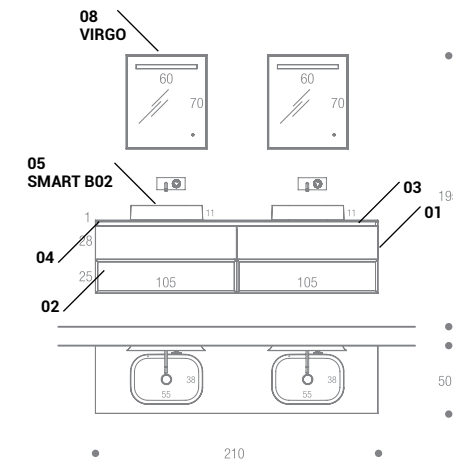

_01_03_04 Dekorativo 3D Castagno Scuro (1C3)
_02 Laccato opaco Lavagna (2A9)
_05 Ceramica Bianca Opaca (OCB)
_08 Alluminio verniciato Nero opaco (203)

M₃ System

C 318 Var pages 214-217

04 | Top Sp. 1 cm Dekorativo 3D Noce Canaletto Naturale (1N2) ___Top Th. 1 cm Dekorativo 3D Noce Canaletto Naturale (1N2) ___Plan Ép. 1 cm Dekorativo 3D Noce Canaletto Naturale (1N2) ___Platte St. 1 cm Dekorativo 3D Noce Canaletto Naturale (1N2) ___Encimera Esp. 1 cm Dekorativo 3D Noce Canaletto Naturale (1N2)

05 | Lavabo Tutto Fuori SMART B02 L. 55 P. 38 Ceramica Bianco Opaco (OCB) ___SMART B 02 Sit-on Washbasin W. 55 P. 38 Matt White Ceramic ___Vasque à poser SMART B 02 L. 55 P. 38 Céramique Blanche Mate ___Aufsatzbecken SMART B 02 L. 55 P. 38 mattweißer Keramik ___Lavabo externo SMART B 02 L. 55 P. 38 Cerámica Blanca Opaca

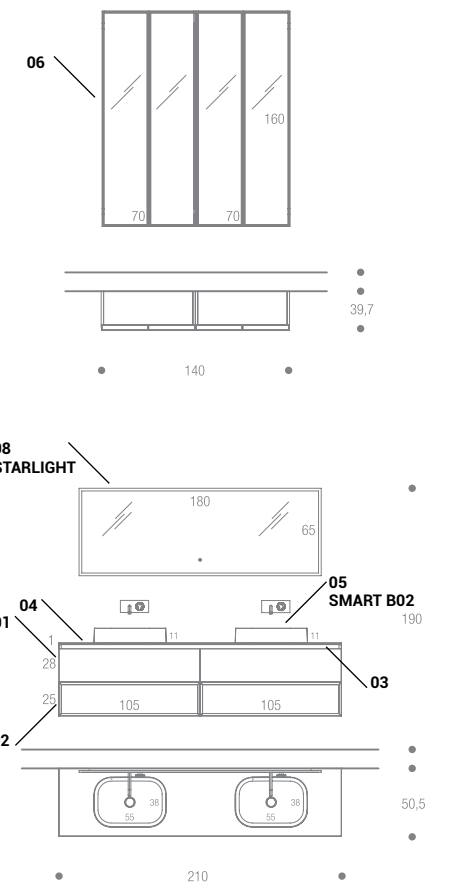

_01_03_04 Dekorativo 3D Noce Canaletto Naturale (1N2)
_02 Laccato opaco Grigio Talpa opaco (2B5)
_05 Ceramica Bianca Opaca (OCB)
_06 Alluminio verniciato Creta opaco (2M6)
_06 Vetro stop-sol grigio (04K)

M3 System

Summary



Baxar

Gennaio 2024

AD: sciutoarchitetti.it

Concept grafico e testi: **Regia**
Photo / 3D: **Gabriotti Fotografi**
Stylist: **Carla Bernardis**

Fotolito: **Luce group**
Printed in Italy by: **Grafiche Antiga**

BAXAR by Azzurra Group s.r.l.
33087 Cecchini di Pasiano (PN) Italia
Via Codopè, 62
tel. +39 0434 610347
fax +39 0434 611066
info@baxarbagni.com
www.baxarbagni.com

É vietata la riproduzione, anche parziale,
di questo catalogo in qualsiasi forma o su
qualsiasi supporto senza l'autorizzazione
di Azzurra Group s.r.l.

Total or partial reproduction by any means
of this catalogue is forbidden without
autohorization fromm Azzurra Group s.r.l.

BAXAR

BATHROOMS

SHAPES

RITUALS